

JM.3 ESA

JM.4 ESA

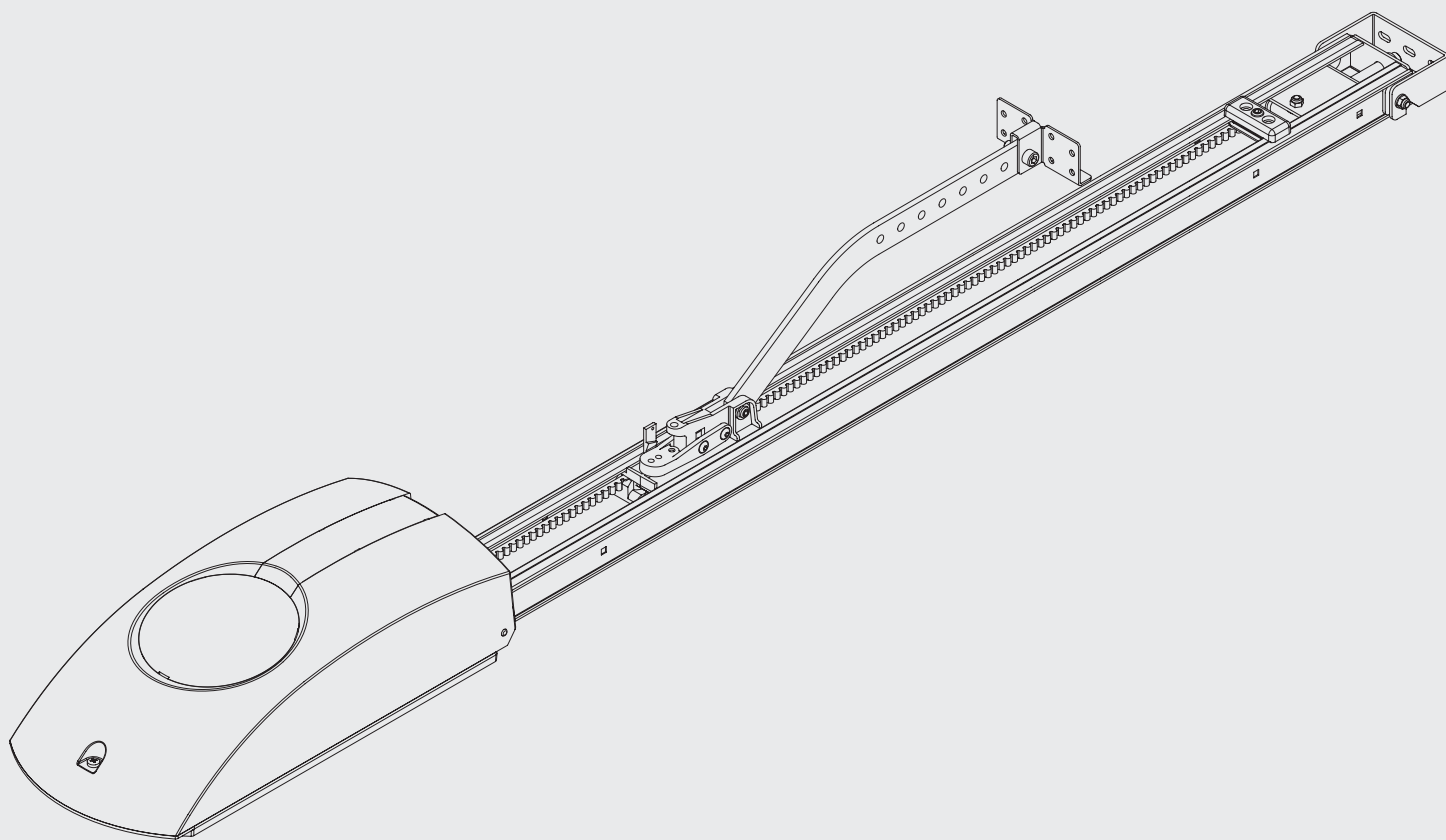

BENINCA[®]
TECHNOLOGY TO OPEN



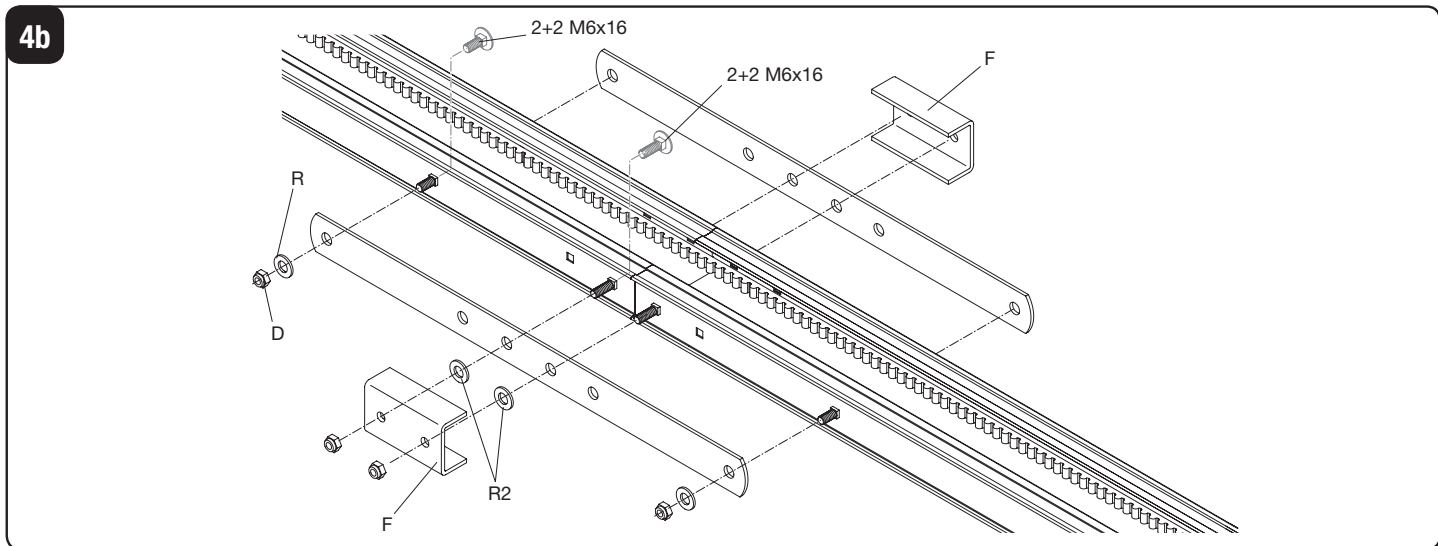
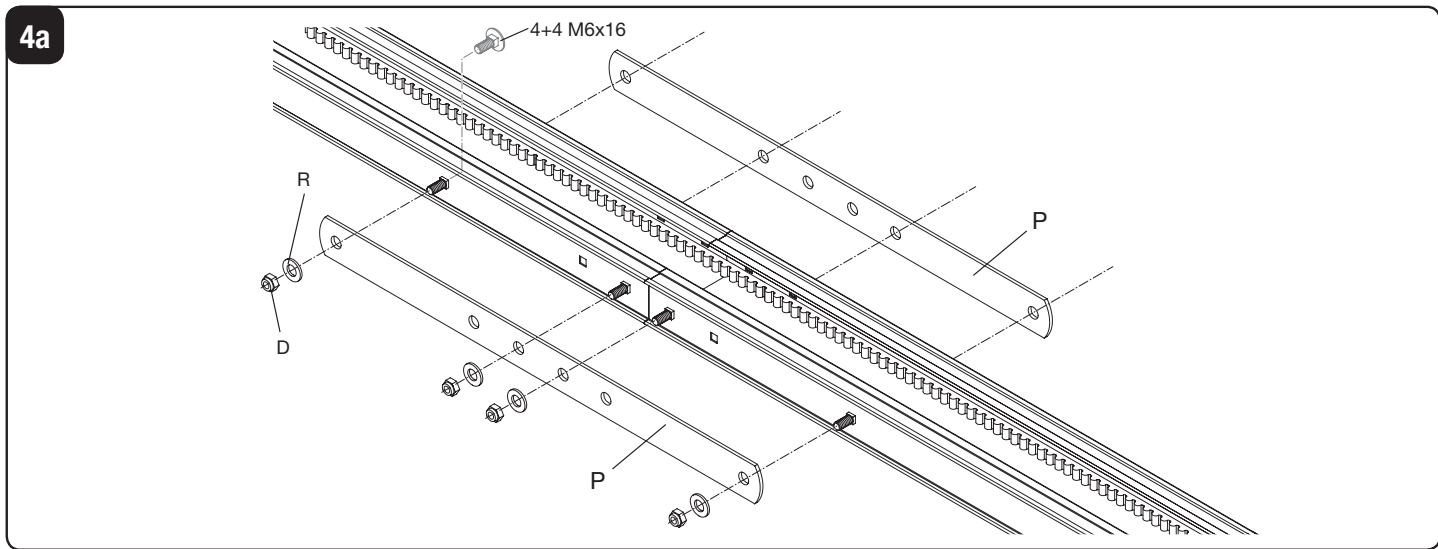
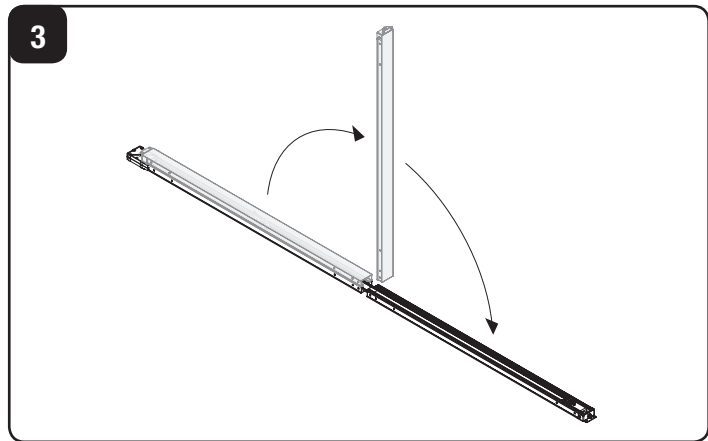
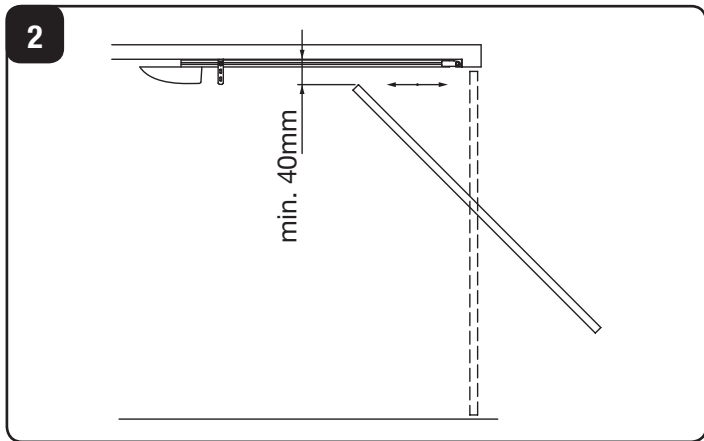
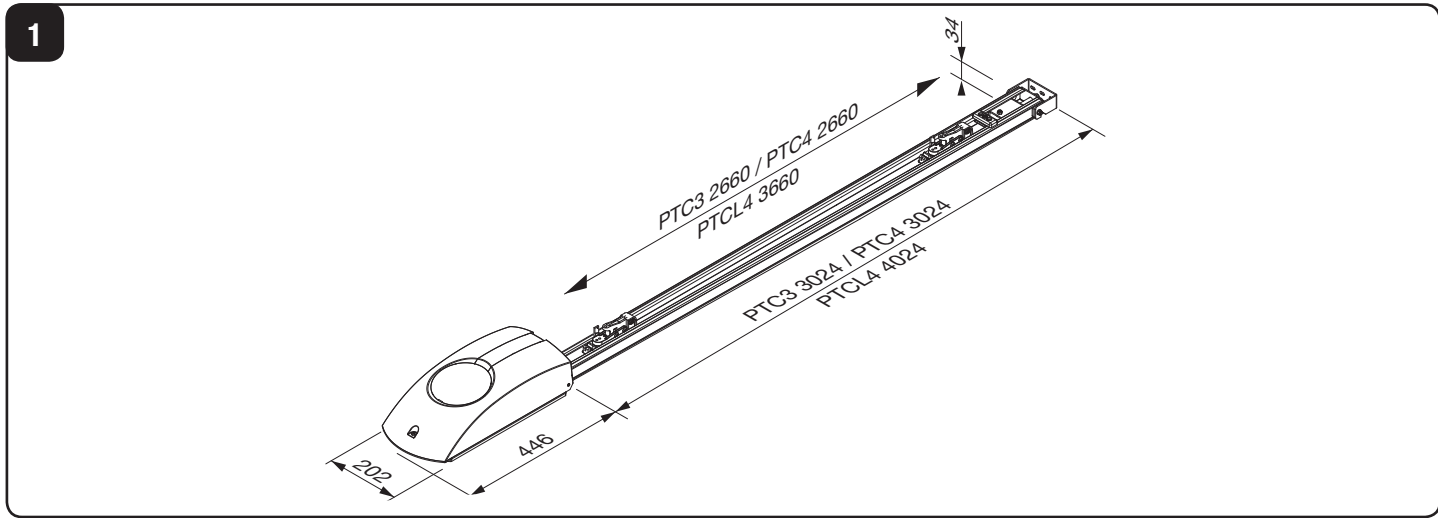

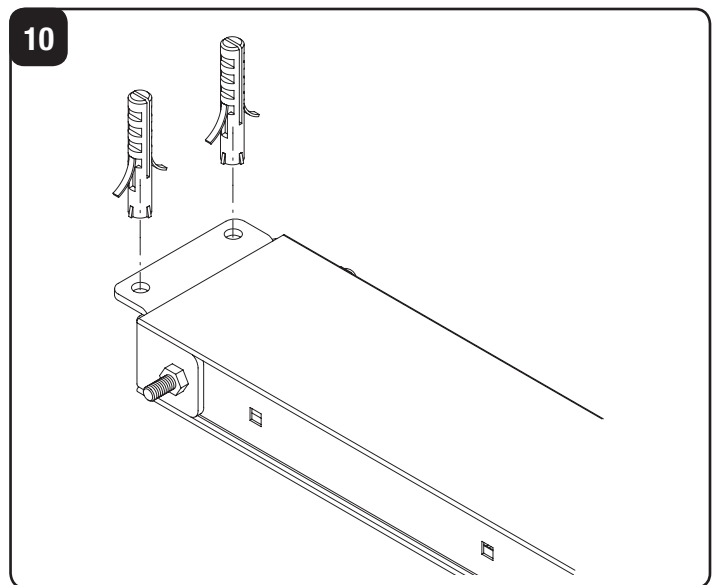
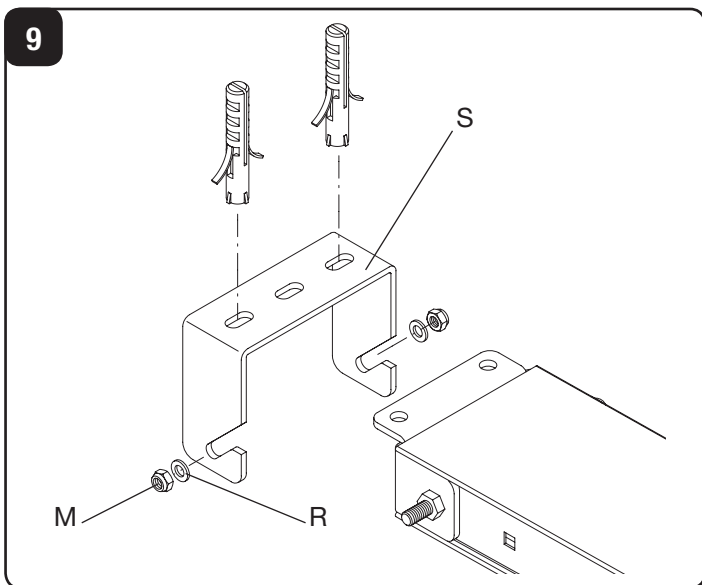
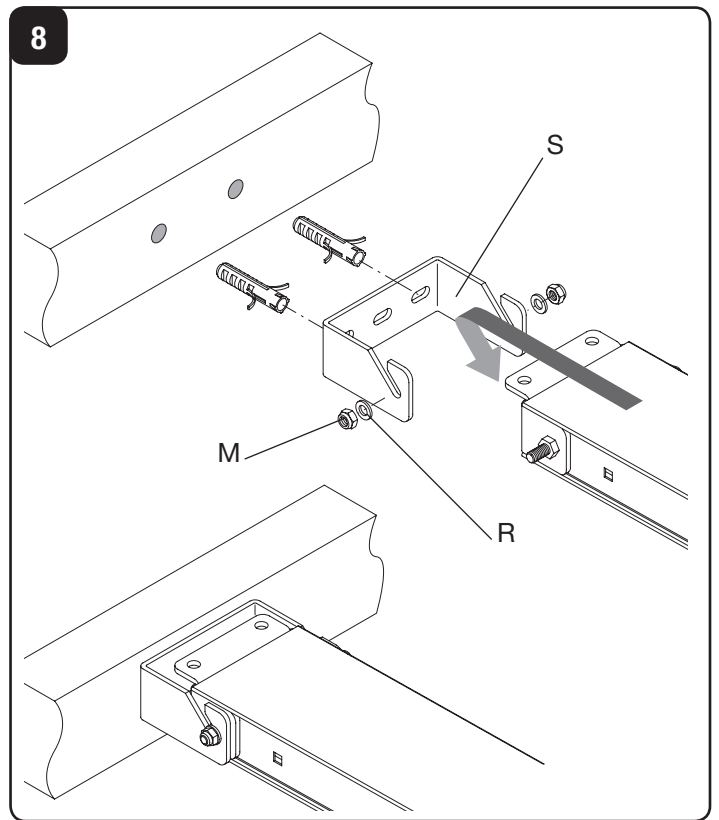
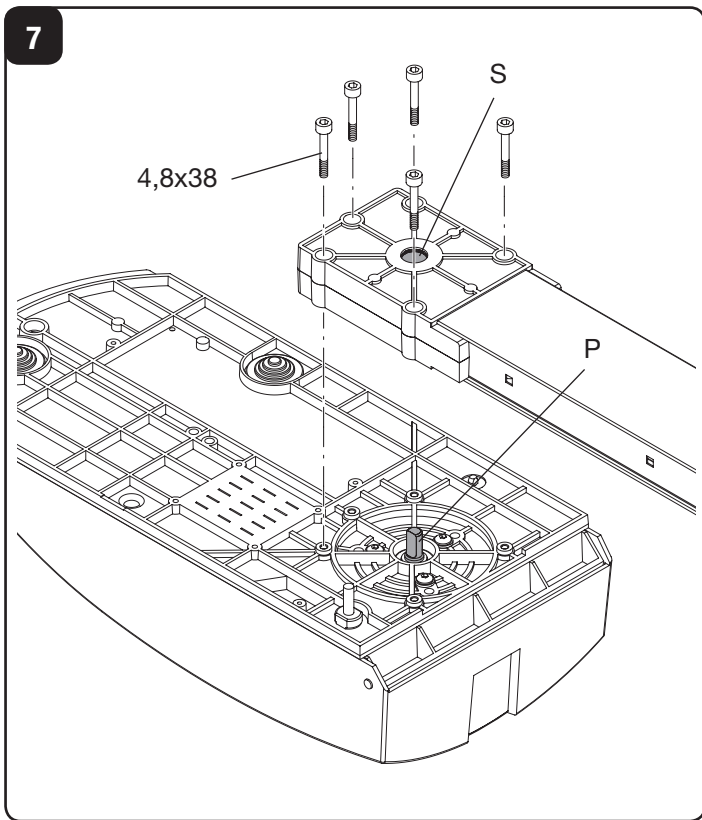
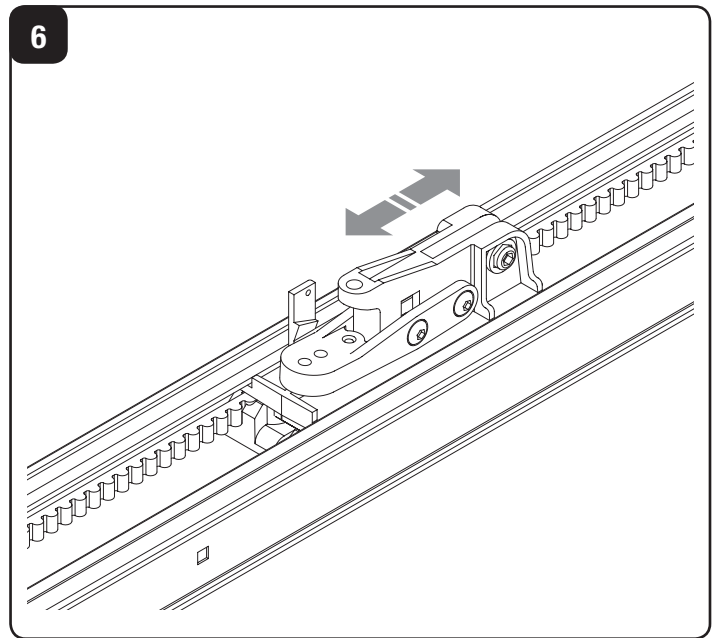
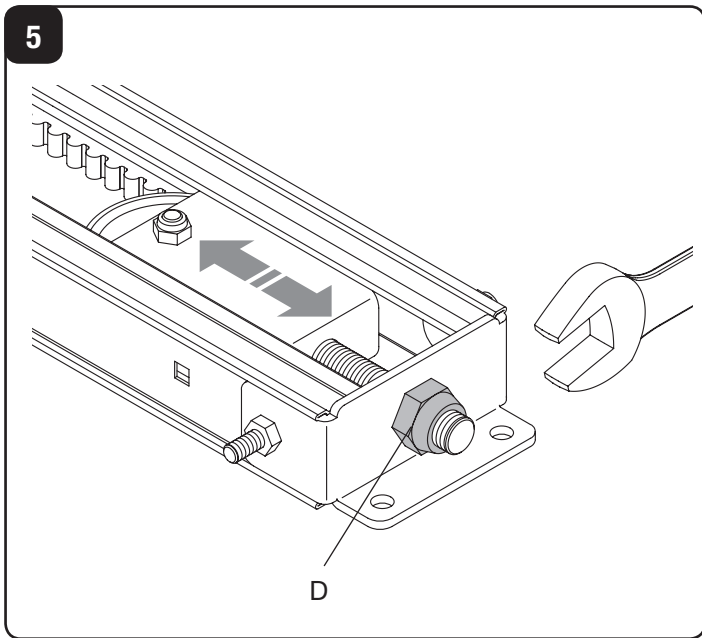

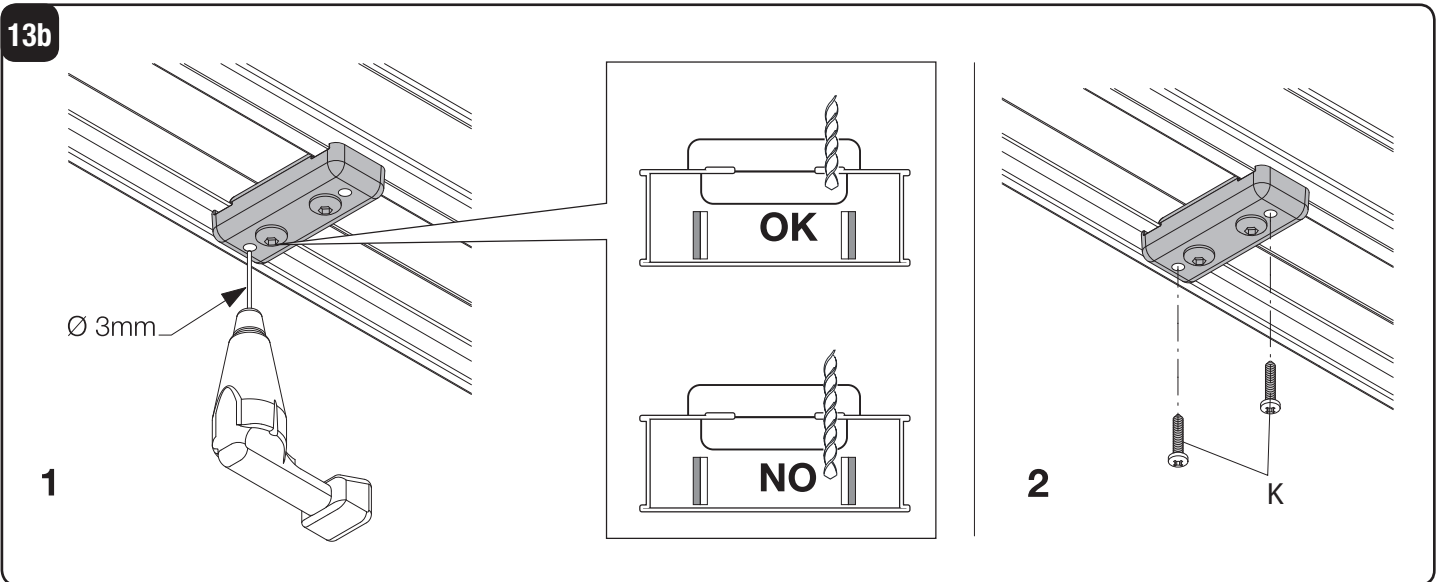
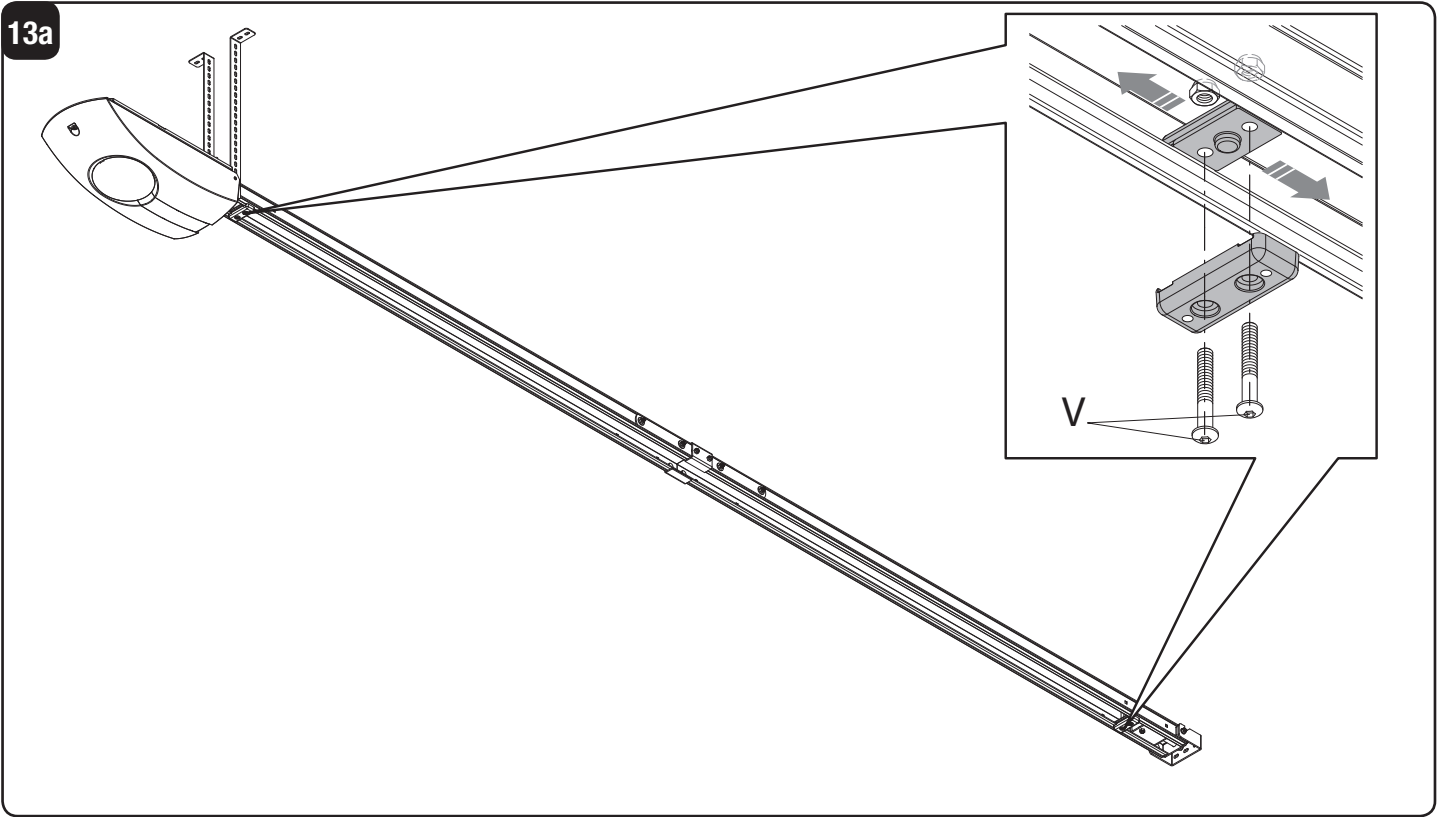
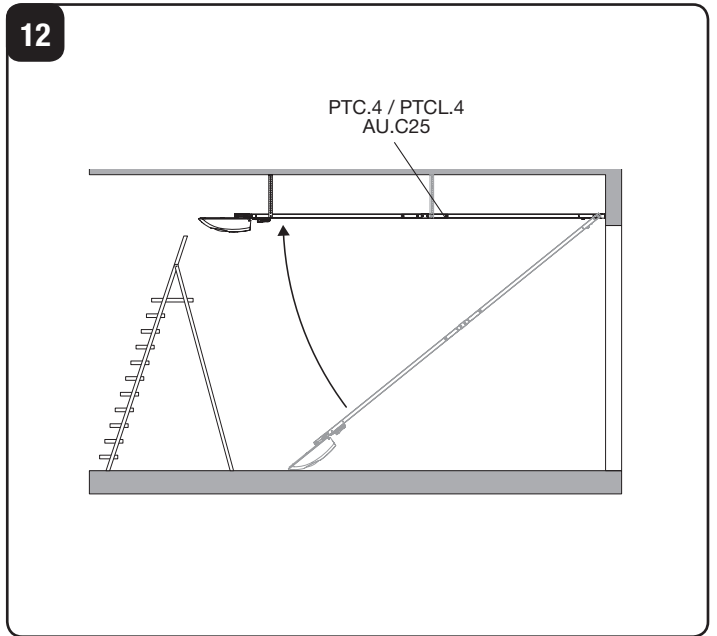
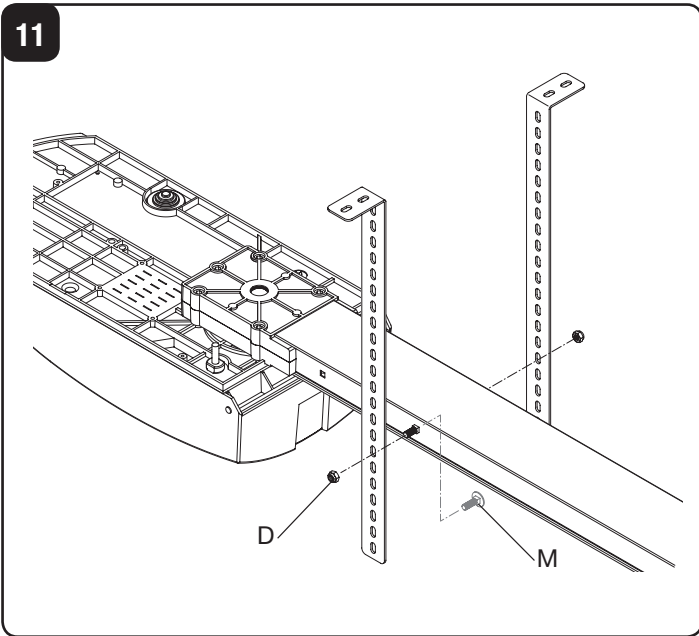

14

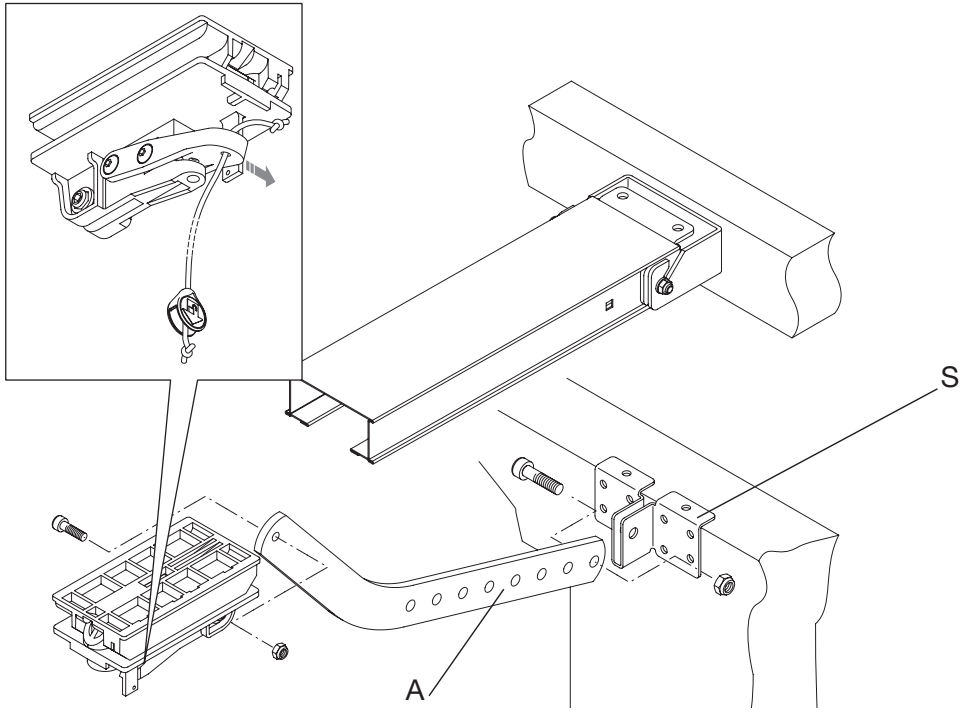

16

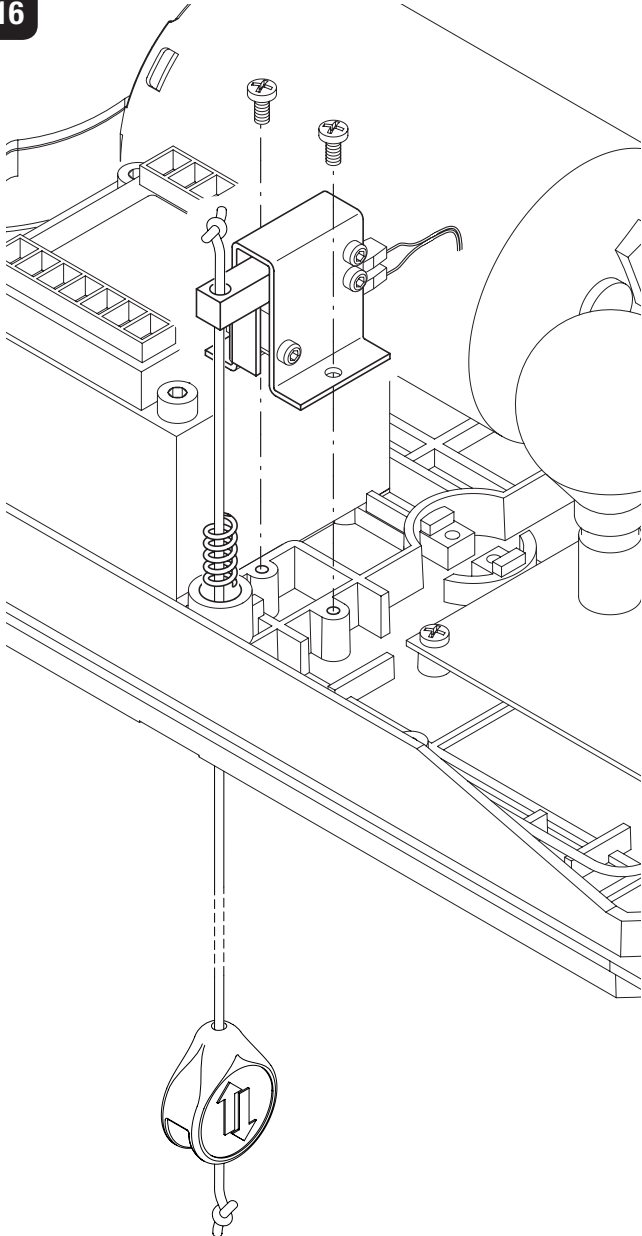

17

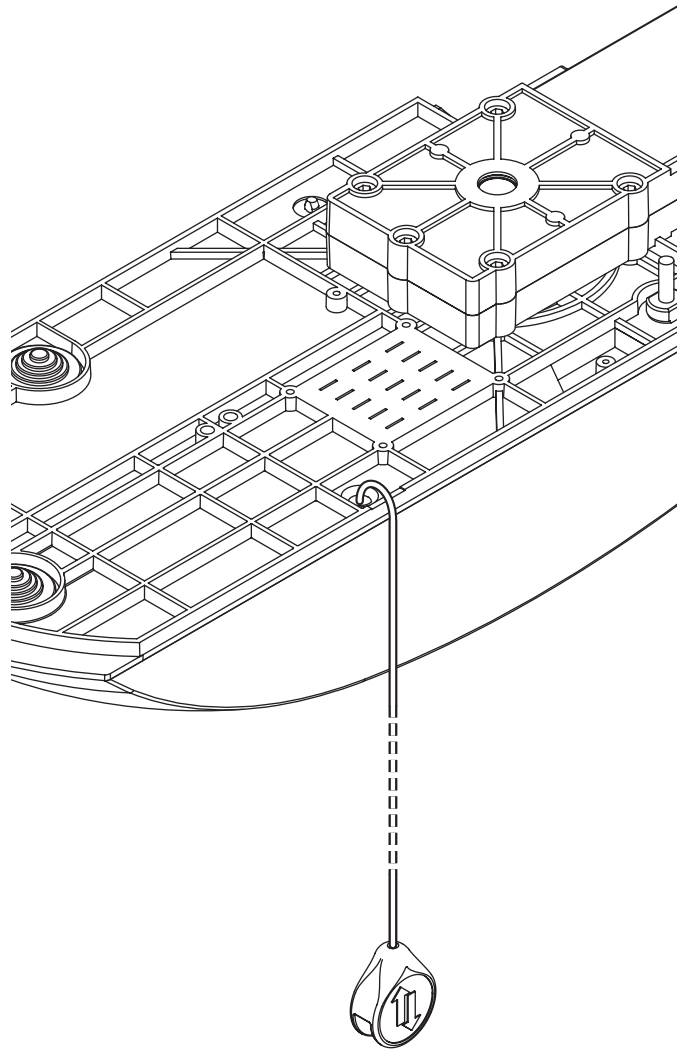

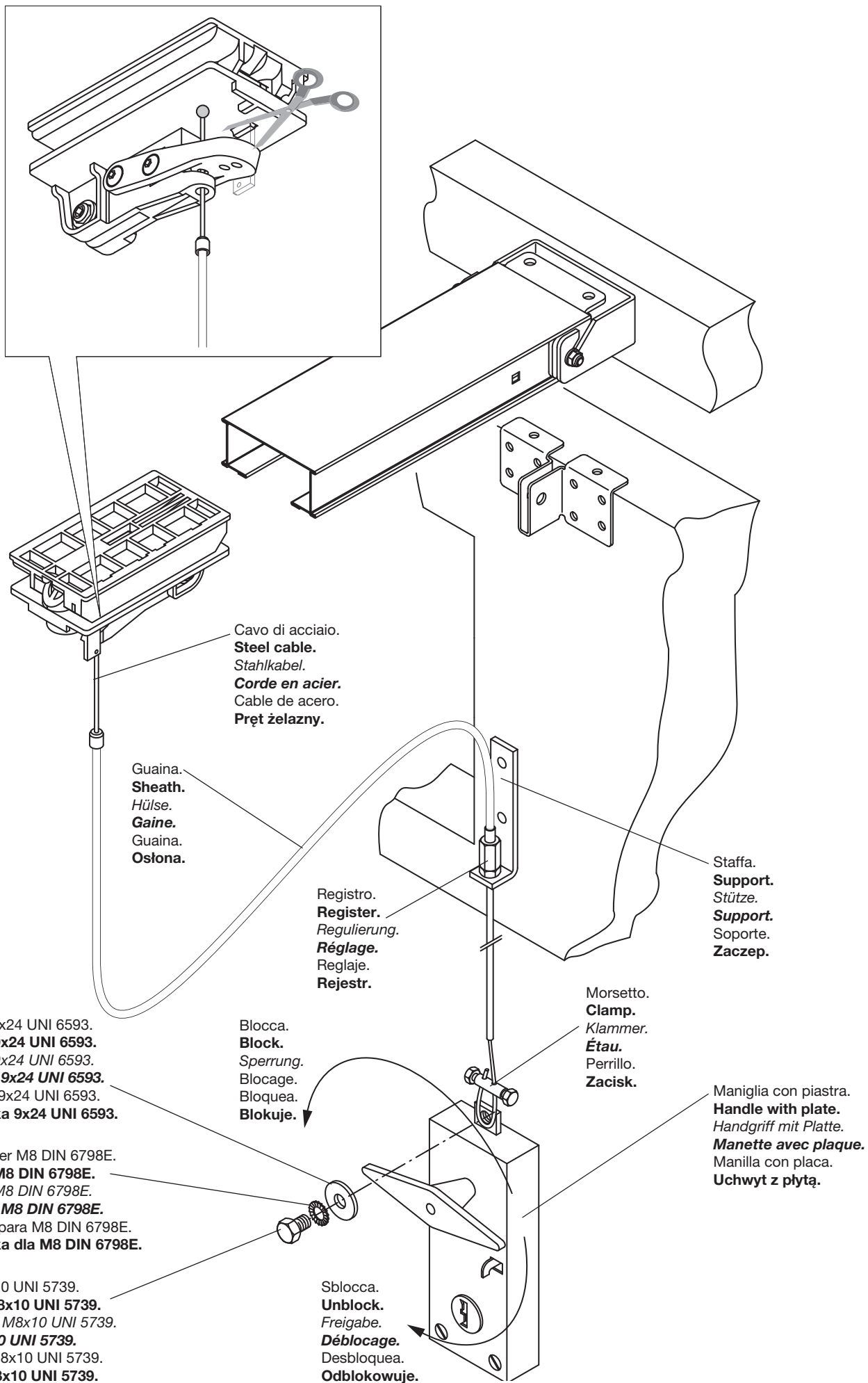

Fissare il braccio sul filo superiore della porta.
Fix the arm to the top edge of the door.
Arm an der oberen Kante des Tores befestigen
Fixer le bras sur l'arête supérieure de la porte.
 Fijar el brazo en la arista superior de la puerta.
Przymocować ramię do górnego prętu bramy.

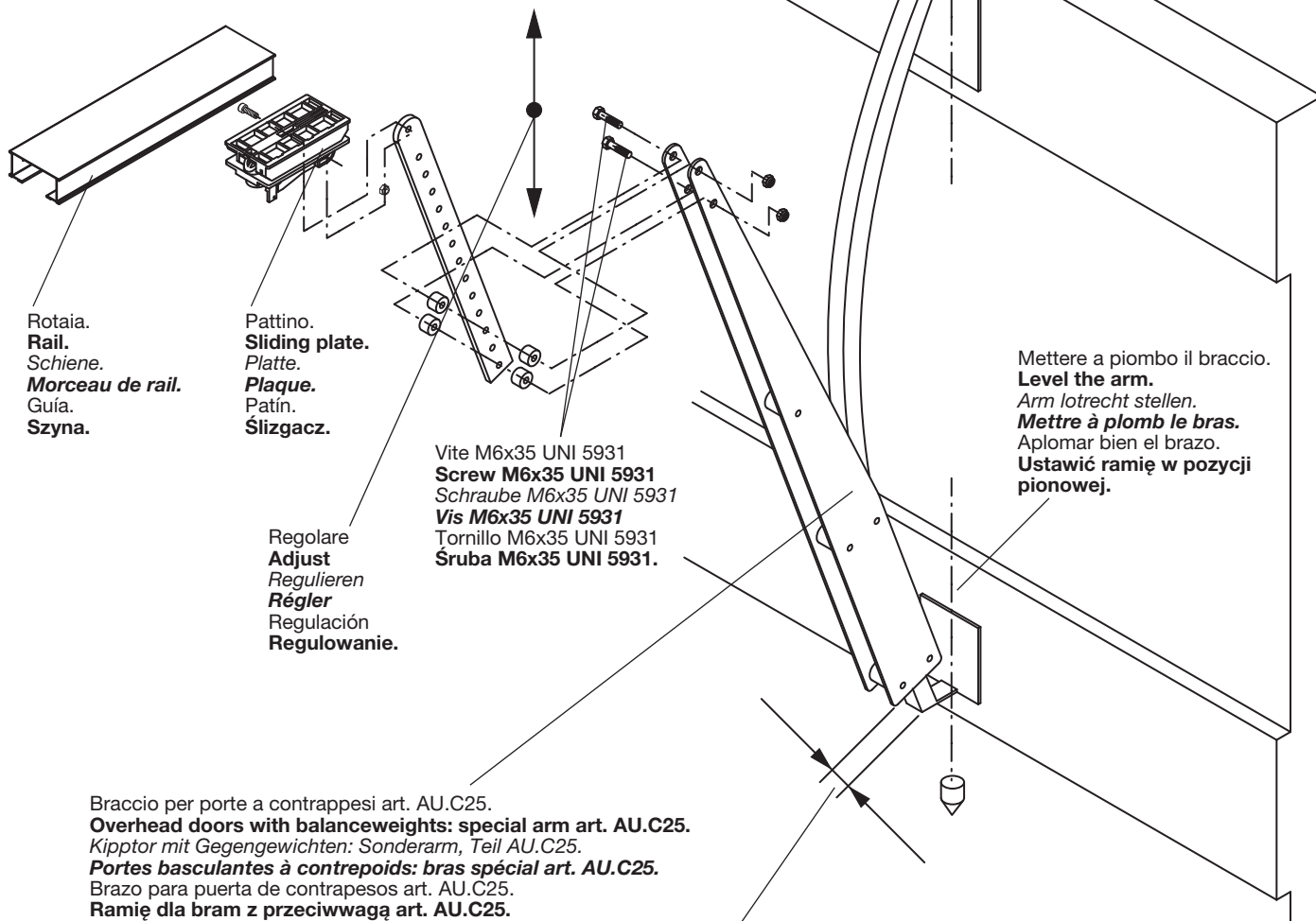

A porta chiusa lasciare 2 ÷ 3 cm.
Keep a distance of 2 ÷ 3 cm when the door is closed.
Wenn die Tür geschlossen ist, lassen 2 ÷ 3 cm.
Il faut laisser 2 ÷ 3 cm quand la porte est ouverte.
 Cuando la puerta ésta cerrada, hay que haber 2 ÷ 3 cm.
Podczas zamkniętej bramy pozostawić 2 ÷ 3 cm.

EC Declaration of Conformity

Directive 2004/108/EC(EMC); 2006/95/EC (LVD)

Manufacturer:

Automatismi Benincà SpA.

Address:

Via Capitello, 45 - 36066 Sandrigo (VI) – Italy

It is hereby stated that the product

pulling automatic system for sectional doors model

JM.3 ESA/JM.4 ESA.

is compliant with provisions set forth in the following EC Directives:

- **DIRECTIVE 2004/108/EC OF THE EUROPEAN PARLIAMENT AND OF THE COUNCIL** of 15 December 2004, on the harmonisation of the laws of Member States relating to electromagnetic compatibility and which cancels Directive 89/336/EEC, according to the following harmonised regulations: EN 61000-6-2:2005, EN 61000-6-3:2007.

- **DIRECTIVE 2006/95/EC OF THE EUROPEAN PARLIAMENT AND OF THE COUNCIL** of 12 December 2006, on the harmonisation of the laws of Member States relating to electrical equipment designed for use with certain voltage limits, according to the following harmonised regulations: EN 60335-1:2002 + A1:2004 + A11:2004 + A12:2006 + A2:2006 + A13:2008; EN 60335-2-103:2003.

- **DIRECTIVE 2006/42/EC OF THE EUROPEAN PARLIAMENT AND OF THE COUNCIL** of 17 May 2006, on machinery, which amends Directive 95/16/EC, and complies with the requisites for the “partly completed machinery (almost machinery)” set forth in the EN13241-1:2003 regulation.

• Moreover, **Automatismi Benincà SpA** declares that the pertaining technical documentation has been drawn up in compliance with Attachment VII B of the 2006/42/ EC Directive and that the following requirements have been complied with: 1.1.1 - 1.1.2 - 1.1.3 - 1.1.5 - 1.2.1 - 1.2.3 - 1.2.6 - 1.3.1 - 1.3.2 - 1.3.3 - 1.3.4 - 1.3.7 - 1.3.9 - 1.5.1 - 1.5.2 - 1.5.4 - 1.5.5 - 1.5.6 - 1.5.7 - 1.5.8 - 1.5.10 - 1.5.11 - 1.5.13 - 1.6.1 - 1.6.2 - 1.6.4 - 1.7.2 - 1.7.4 - 1.7.4.1 - 1.7.4.2 - 1.7.4.3.

• The manufacturer undertakes that information on the “partly completed machinery” will be sent to domestic authorities. Transmission ways are also included in the undertaking, and the Manufacturer’s intellectual property rights of the “almost machinery” are respected.

• It is highlighted that commissioning of the “partly completed machinery” shall not be provided until the final machinery, in which it should be incorporated, is declared compliant, if applicable, with provisions set forth in the Directive 2006/42/EC on Machinery.

• Moreover, the product, as applicable, is compliant with the following regulations: EN 12445:2002, EN 12453:2002, EN 12978:2003.

Benincà Luigi, Legal Officer.

Sandrigo, 22 November 2010.

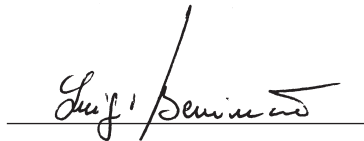

WARNING

The product shall not be used for purposes or in ways other than those for which the product is intended for and as described in this manual. Incorrect uses can damage the product and cause injuries and damages.

The company shall not be deemed responsible for the non-compliance with a good manufacture technique of gates as well as for any deformation, which might occur during use.

Keep this manual for further use.

Qualified personnel, in compliance with regulations in force, shall install the system.

Packaging must be kept out of reach of children, as it can be hazardous. For disposal, packaging must be divided the various types of waste (e.g. carton board, polystyrene) in compliance with regulations in force.

The installer must supply all information on the automatic, manual and emergency operation of the automatic system and supply the end user with instructions for use.



An omnipolar switch/section switch with remote contact opening equal to, or higher than 3mm must be provided on the power supply mains.. Make sure that before wiring an adequate differential switch and an overcurrent protection is provided.

Pursuant to safety regulations in force, some types of installation require that the gate connection be earthed.

During installation, maintenance and repair, cut off power supply before accessing to live parts.

Descriptions and figures in this manual are not binding. While leaving the essential characteristics of the product unchanged, the manufacturer reserves the right to modify the same under the technical, design or commercial point of view without necessarily update this manual.

Introduction

Thank you for choosing our **JM.3 ESA/JM.4 ESA** ratiomotor.

All items in the wide Benincà production range are the result of twenty-years' experience in the automatism sector and of continuous research for new materials and advanced technologies.

We are, therefore, in the position to offer highly reliable products that due to their power, effectiveness and useful life, fully satisfy the final user's requirements.

All our products are covered by warranty.

Possible injury to people or accidents caused by defects in construction are covered by a civil liability policy drawn up with one of the major insurance companies.

1. General information

The system has been studied to motorize sectional doors.

To be applied onto balancing doors, a special fitting arm is required (item AU.C25).

In any case, following conditions will have to be observed:

- the distance between the door highest point and the ceiling must be at least 40mm (fig. 2).
- it has to be possible to open and close the door by pulling and pushing horizontally its top edge (fig.2).
- manual moves must be smooth and regular.

The gear motor is available in two versions:

JM.3 ESA (600Nm) and **JM.4 ESA (1200Nm)** to which the following tracks can be matched (fig.1):

PTC.3: Pre-assembled track, with **8 mm** belt, **2.5m** max height, for **JM.3 ESA** only

PTC.4: Pre-assembled track, with **10 mm** belt, for doors with **2.5 m** max height, for **JM.3 ESA** and **JM.4 ESA**

PTC.L4: Pre-assembled track, with **10mm** belt, for doors with **3.5 m** max height, for **JM.3 ESA** and **JM.4 ESA**

Technical data	JM.3 ESA	JM.4 ESA
Feed	230Vac	230Vac
Motor feed	24Vdc	24Vdc
Absorbed rating	150W	315W
Drive speed	8,9 m/min	8,9 m/min
Drive/thrust force	600N	1200N
Degree of protection	IP40	IP40
Jogging	Intensive Use	Intensive Use
Operating temp.	-20°C/+70°C	-20°C/+70°C
Noise level	<70dB (A)	<70dB (A)
Max. door height:		
with PTC3/PTC4	2,5m	2,5m
with PTCL4	3,5m	3,5m
Power unit weight	6,2 kg	7,6 kg
Total weight:		
with PTC3/PTC4	11,8kg	13kg
with PTCL4	13,6kg	15kg

2. Installation

- a) Place the track on a flat surface and lay it as shown in Fig.3
- b) Referring to Fig. 4, align both ends of the tracks and fit them with the two plates P, by using the eight M6X16 screws, the nuts D and the washers R.
- c) Make sure that the belt is correctly tensioned. If necessary, it can be adjusted through nut D, as shown in Fig.5.
The correctly tensioned belt keeps its position along the entire track, without bending, but still resilient at a slight

pressure by hand.

- d) Move the drive carrier (Fig.6) until the pulley housing (ref. S of Fig. 7) touches the motor shaft pin (ref. P of Fig. 7)
- e) Fix the track to the basis of the gear motor, as per Fig.7. Fit the track to the basis of the gear motor, with the five D4,8x38 screws.
- f) Fit the hooking bracket S to wall (Fig.8) or ceiling (Fig.9). Mark the two fitting points corresponding to the centre of the door. Hook the track to the bracket and fix it by means of nuts M and washers R. Rest the gear motor body on the floor.
If there is not enough space to use the bracket S, the track can be fixed directly to the ceiling through the holes shown in Fig.10.
- g) Position the fitting brackets to ceiling by means of the special housings in the track, near the gear motor (Fig.11) and fix them by means of screws M and nuts D. Two fitting brackets for mounting to ceiling are supplied with PTC.4 and PTC.L4 tracks. They must be fitted near the joining point of the tracks.
- h) By using a ladder, hoist the gear motor (Fig.12), mark the fitting points of the brackets, drill the holes and fix the gear motor by means of screws and screw anchors suited to the material.
- i) temporarily fix the opening and closing mechanical stoppers, at beginning and end of track, by using the screws K, as highlighted in Fig.13a. At the end of the adjustment phase of the automatic system, the stoppers will be positioned more precisely and firmly fixed to the track between the 2 screws X, while drilling two holes, as indicated in Fig. 13b.
Note: while making the holes, take care not to drill the stoppers as well.
- l) Connect the driving rod A to the drive slide by means of the M6x20 cylinder head screws and the self-tapping nut. The rod movement should not be obstructed. Fix the bracket S to the door so that, with closed door, the rod A is in an almost vertical position. Shorten the drive rod A, if required.
In the event of heavy doors, it is recommended to use both upper and front holes.
- m) Insert the cord in the release lever and in the knob. Make a knot as indicated in the detail of Fig.14.
- n) Apply the warning sticker supplied to the door:



3. How to store the opening and closing positions in memory

The gear motor is equipped with a control unit with a memorisation function of the opening and closing positions. The memorisation procedure is described in instructions supplied with the control unit and requires the positioning of the mechanical stoppers, cf. Fig.13.

4. Speed adjustment

The door speed is controlled by the control unit. Please refer to special instructions.

WARNING!: The adjustment of the door movement speed affects the safety level of the automatic system. Comply with regulations in force.

5. Accessories (optional)

JM.CB Emergency Battery Kit:

It permits the operation of the automatic system in the event of power failure.

The kit is composed of: battery charge card, 2 batteries at 12V, fitting bracket, screws and cables.

The batteries must be installed on the upper part of the gear motor basis, as per Fig.16.

To connect batteries, please refer to specific instructions.

Note: Once installed, the batteries protrude from the track upper profile by approx. 10mm.

JM.PP Cord Manual Control:

It permits the control of the automatic system from indoor by means of a cord, thus avoiding the installation of a keyboard.

The kit is composed of: micro-switch group, cord control with knob, spring and cables (Fig.16)

For the installation, please refer to specific instructions.

Fig.17 shows the cord in working position.

6. Manual operation from outdoor

In sectional doors, the system can be released also from outdoor by using item JM.SF (Fig.18).

A.Insert the metal cable in the slide, as indicated in Figure 18.

B.Fit the adjuster on the bracket and insert the sheath.

C.Fix the other end of the cable to the release device. The figure shows an example of connection to the garage door handle AU.MS.

N.B.: Any type of cord release device can be used under the condition that the release stroke is of at least 15 mm.

If the device is able to keep the lever in the release position (e.g. AU.MS) it would be easier to cut the hooking lever, as shown in the detail of Fig. 18. In this way, by moving the handle in the original position, the automatic operation is reset.

7. Assembling onto balancing doors

Overhead door with balanceweights (fig.19): these doors need the special arm art. AU.C25.

In order to assemble it make sure that:

- the arm is fixed to the top edge of the door.
- the arm is levelled.

CAUTION

The civil liability policy, which covers possible injuries to people or accidents caused by defects in construction, requires to use original Benincà accessories.