

**CONTROL UNIT
SERIAL CONVERTER**

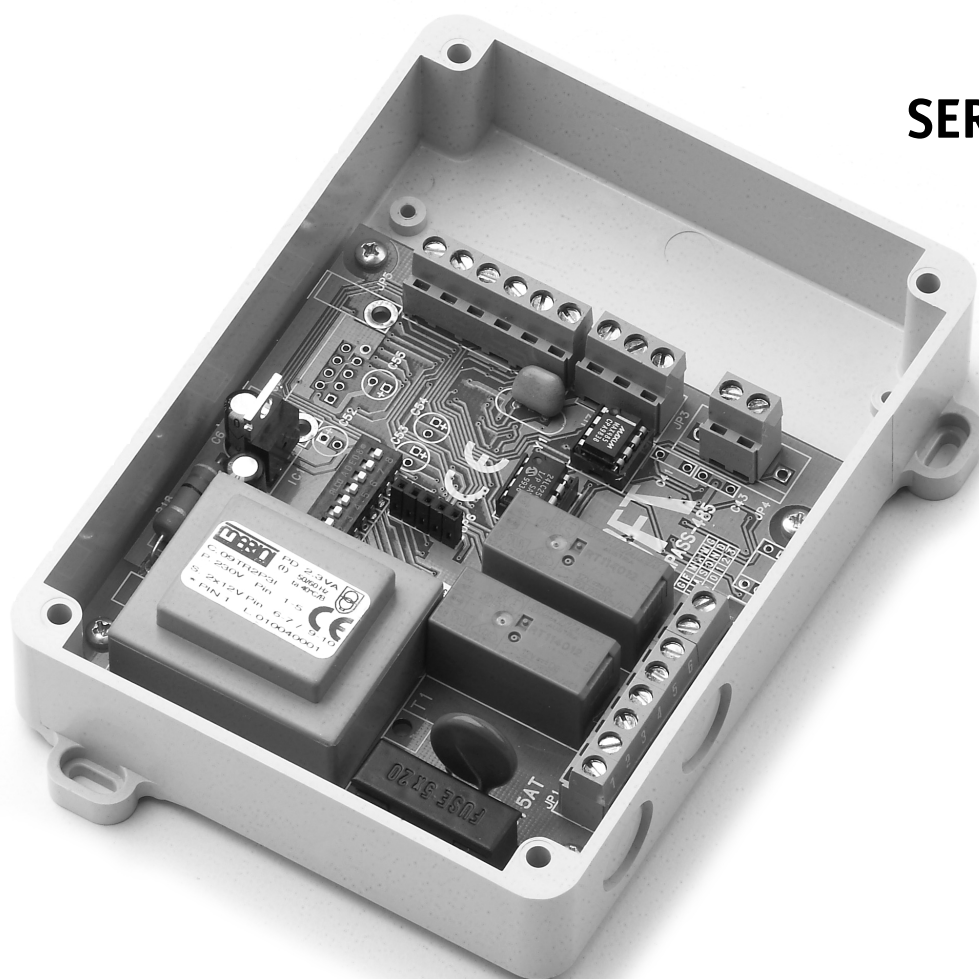

Thank you for buying this product, our company is sure that you will be more than satisfied with the product's performance. The product is supplied with a "Warnings" leaflet and an "Instruction booklet". These should both be read carefully as they provide important information about safety, installation, operation and maintenance. This product complies with the recognised technical standards and safety regulations. We declare that this product is in conformity with the following European Directives: 89/336/EEC and 73/23/EEC (and subsequent amendments).

1) GENERAL OUTLINE

COMPASS-485 is a transponder control card to be used in conjunction with the proximity **COMPASS-READER**. It is used for the control of internal and external access to public and private buildings, hotels, large communities, etc.

The system can be interfaced by using **COMPASS-232** with a PC featuring the **SECURBASE** software which allows total access monitoring. Thanks to its particular construction characteristics **COMPASS-485/COMPASS-READER** is especially useful for controlling access both inside and outside the building.

Accessories:

COMPASS-ISOCARD: ISO standard proximity card, with the possibility of setting personalised data (photograph, personal data, etc.)

COMPASS-RING: Key-ring with transponder with the same functions as the card.

MITTO2-T/MITTO4-T: Rolling-code transmitter with transponder, supplied with the same functions as those of the card.

The main characteristics of the **COMPASS-485/COMPASS-READER** are the following:

- Access to proximity card
- The system parameters and the code map are stored in a non-volatile storage which can file the stored data for years even in the event of power supply failure.
- The memory can handle up to 6000 cards.
- The opening time can be set freely from 1 to 25.5 seconds.
- The door-open control time can be set freely from 1 to 250 seconds.
- Input for door opening button and threshold status input (open/closed)
- ABS box with wearproof multilayer membrane protected against atmospheric agents.

2) TECHNICAL DATA

Power supply: 230 V~ ±10% 50/60Hz

Dimensions: See Fig.1

Protection level of Compass-485: IP20(*)

Protection level of Compass-232: IP20(*)

Rated temperature: -20°C +60°C

Opening time: from 1 to 25.5 secs.

No. of cards that can be memorised: up to 6,000

(*) The level of protection of the casing becomes IP55 when a special accessory is used, which can be supplied on request. Utilise only connections suitable to the dimensions of the container and the diameter of the cable.

3) ASSEMBLY (Fig.2)

After laying down the cables for connection, fasten the support (fig.2) marking the two holes using the slots provided on the container as template. Use the screws supplied directly or make a 4mm hole to insert the anchors supplied depending on the material the support is made of. Tighten the screws completely and correct any centering difference using the slots on the container.

WARNING! The COMPASS-485 control card controls the opening of the door by means of a relay.

A safe installation therefore includes:

- 1 - the positioning of the **COMPASS-READER** outside the building, which guarantees that the door can be opened even in the event of tampering.
- 2 - the positioning of the **COMPASS-485** control inside the building, which guarantees that the door can be opened only after a valid card has been shown and read by the **COMPASS-READER**.

4) WIRING DIAGRAM

The module contains four connection terminal strips. For connection, refer to the diagram in Fig.3.

JP1a

1 - Power supply (L)

2 - Power supply (N)

Power supply input 230 V~ ±10% 50/60Hz

JP1b

WARNING! To keep unaltered the electrical insulation, do not connect devices supplied with mains or low-tension voltage to the JP1b terminal board at the same time.

3 - Output for COM Common Contact

4 - Output for NO normally open contact

Ccontact for door opening piloting. After the card is recognised and activated, the closing between COM and NO takes place.

5 - Output for NC normally closed contact, invalid card alarm

6 - Output for COM common contact, invalid card alarm

7 - Output for NO normally open contact, invalid card alarm

Exchange contact for alarm piloting. After the door is opened and this is not closed within the "door-open control time", the exchange between NC and NO takes place.

JP4

8 - Serial RS 485

9 - Serial RS 485

Permit the serial connection of several **COMPASS 485** in the systems interfaced by means of the **Compass 232** with the COM serial port of a PC (see Fig. 4). It is recommended not to use a connection length of more than 500 m.

JP3

- 10 - Open and Door input common wire
- 11 - N.O. Contact OPEN (controls manual door opening)
- 12 - Contact DOOR (door status input) NC – Door closed NO – Door open
(detects the status of the door needed to identify the alarm condition; if not used, leave the jumper connected)

JP2 (COMPASS-READER connection)

- 13 - + Power supply
- 14 - Date 1
- 15 - Date Ø
- 16 - - Power supply
- 17 - Led A
- 18 - Led B

Receives from COMPASS-READER the data of the card inserted.

It is possible to connect a maximum of 2 COMPASS-READERS to each COMPASS-485 (Fig. 3).

5) GENERATION OF MASTER CARDS

The system is controlled by three Master Cards (Master Card +, Master Card -, Master Card Jolly) which activate or deactivate the cards and configure the functioning of access as indicated in the paragraph "Configuration of the Parameters and Management of the Cards"

To generate the Master Cards, proceed as follows:

- 1 Open the COMPASS-485 box
- 2 Set the Dip Switch 6 to ON (Fig.3)
- 3 Show a Standard Card (the Led will flash changing from red to green continuously)
- 4 Set the Dip 6 to OFF
- 5 The Card has now become a Master Card +, attach the supplied special adhesive label (green colour, symbol +) which will help to identify the type of Master Card.
- 6 Set the Dip Switch 7 to ON (Fig.3)
- 7 Show a Standard Card (the Led will flash changing from red to green continuously)
- 8 Set the Dip 7 to OFF
- 9 The Card has now become a Master Card -, attach the supplied special adhesive label (red colour, symbol -), which will help to identify the type of Master Card.
- 10 Set the Dip Switch 8 to ON (Fig.3)
- 11 Show a Standard Card (the Led will flash changing from red to green continuously)
- 12 Set the Dip 8 to OFF
- 13 The Card has now become a Master Card Jolly, attach the supplied special adhesive label (yellow colour, symbol Jolly), which will help to identify the type of Master Card.
- 14 Close the COMPASS-485 box.

The Master Cards therefore allow the configuration of the system.

After using the Master Cards, place them in a safe place known only by assigned personnel along with the instructions for use.

6) CONFIGURATION OF THE PARAMETERS AND MANAGEMENT OF THE CARDS

The configuration of the parameters and card activation are obtained by showing the sequence of the Master Cards and Cards to be activated or deactivated observing the following procedure:

- **Card activation:**
Show the **Master Card +** to the reader (the Led will flash changing from red to green continuously) followed by the card for which access activation is required (the Led turns to yellow)
- **Card deactivation:**
Show the **Master Card -** to the reader (the Led will flash changing from red to green continuously) followed by the card for which access deactivation is required (the Led turns to yellow)
If it becomes necessary to deactivate a card that has been mislaid there are two ways of doing so:
 - If the system is controlled by Securbase and the card code is known (all cards are supplied with a printed 6-digit code), deactivation can be obtained by using the card software and entering the code to be deactivated in the appropriate menu.
 - If the system is not controlled by Securbase or the card code is not known, it is necessary to deactivate all of the cards and then reactivate all valid cards.
- **Free Access (door always open):**
Show the **Master Card Jolly** to the reader (the Led will flash changing from red to green continuously) followed by the **Master Card +** (the Led turns to green)
- **Access Forbidden (door always closed):**
Show the **Master Card Jolly** to the reader followed by the **Master Card -** (the Led turns to red)
- **Access with normal operation mode (opening with memorised cards only):**
Show the **Master Card Jolly** to the reader for two consecutive times (the Led turns to yellow).
- **Setting of Door Relay Operation Time:**
Show the **Master Card +** to the reader (the Led will flash changing from red to green continuously) followed by the **Master Card Jolly** (the green Led flashes), from now on every time the Master Card Jolly is shown the value of the door relay operation time, expressed in seconds, will increase. The sequence of values is the following: 0, 1, 2, 3, 4, 5, 6, 7, 8, 9, 10, 11, 12, 13, 14, 15, 16, 17, 18, 19, 20, 21, 22, 23, 24, 25. After 25 which is equal to 25s, the value goes back to 0.
If the value set is 0, the relay for door opening remains active until the door is closed.
- **Setting of Door Control Time:**
Show the **Master Card -** to the reader (the Led will flash changing from red to green continuously) followed by the **Master Card Jolly** (the red Led flashes), from now on every time the Master Card Jolly is shown the value of the door control time, expressed in seconds, will increase. The sequence of values is the following: 0, 10, 20, 30, 40, 50, 60, 70, 80, 90, 100, 110, 120, 130, 140, 150, 160, 170, 180, 190, 200, 210, 220, 230, 240, 250. After 250 which is equal to 250s, the value goes back to 0. If the value set is 0, the door control is disabled.
Door check: Checks the status of the door using the "DOOR" contact input, ensuring that after the door opening relay is closed, the door is actually opened and then closed again. If opening does not occur after the "door check time", the alarm relay is commuted. If the door is opened, it must be closed again within the "door check time", otherwise the alarm relay is commuted.

- **System reset:**

WARNING! This procedure deletes all activated cards and Master Cards automatically; the operation parameters remain memorised. Show the Master Card three consecutive times (the Led will flash changing continuously from red to yellow). Deletion takes 90 sec. approximately.

NOTE: after showing a Master Card, the system waits for a subsequent card for 3 seconds, after which it goes back to normal operation.

7) DIP SWITCH CONFIGURATION

The COMPASS-485 control includes 8 dip-switches, which can be configured to ON - OFF:

The Dip Switches 1-2-3-4-5 allow the setting of the communication address (polling) of the Compass-485 when used with Compass-232 and PC. For example: all Dip Switches Off = address 0, Dip Switch 1 On only = address 1, Dip Switch 4 On only= address 8, Dip Switch 1+2+5 On= 19. Only the addresses from 0 to 19 are valid and when connecting several Compass-485 units it is essential that the address be univocal in order to avoid conflicts (Fig.4).

Dip 1	ON = 1	OFF= 0
Dip 2	ON = 2	OFF= 0
Dip 3	ON = 4	OFF= 0
Dip 4	ON = 8	OFF= 0
Dip 5	ON = 16	OFF= 0

The table in Fig.5 shows the valid configurations.

The Dip Switches 6 - 7 - 8 are to be used for the generation of the Master cards (see paragraph 5). Upon completion of generation, they must be reset to OFF.

Dip 6 - Generation of Master Card +
ON = Activated (show card) OFF= (deactivated)

Dip 7 - Generation of Master Card -
ON = Activated (show card) OFF= (deactivated)

Dip 8 - Generation of Master Card Jolly
ON = Activated (show card) OFF= (deactivated)

8) CONNECTION OF PC

The system can be interfaced with a personal computer for the complete monitoring of access (Fig.4).

In this case, the following accessories are required:

COMPASS 232 - PC interface: permits the connection of up to 20 COMPASS-485 to a PC (see diagram Fig.4/Fig6).

Furthermore, Compass 232 has all the same functions as the COMPASS-485 and it is therefore possible to connect a Compass-Reader, as shown in Fig. 4, without changing the maximum number of installable COMPASS-READERS (20).

NOTE: Connect a 120 Ohm/0.25W resistor to the COMPASS-485 unit further along the line between terminals 8 and 9, as shown in Fig.6.

SECURBASE - Monitoring software:

- Increases the number of cards which can be memorised and controlled (subject to the PC memory).
- Permits the setting of access time (the user can only have access during pre-established periods of time).
- Permits the setting of access dates (the user can only have access in pre-established days).
- Anti-passback function. By installing the additional COMPASS-READER/485 unit at the exit, the user is obliged to exit before being allowed to re-enter.
- Real-time display of access status.
- Real-time display of data regarding the card's owner.
- Setting of the parameters related to all of the connected readers.
- Recording of access events with possibility of subsequent tracing and printing.
- Control of up to 20 COMPASS-485 units.

The control of cards by Securbase is performed by means of a "system reader" represented by a Compass Reader/485 combination of any kind set by the software as reader for card insertion into the PC. For practical reasons, it is recommended to use as system reader the Compass Reader which is closest to the PC station (for example in fig.4 Compass Reader 0).

WARNING: It is important to make sure that the communication address (polling) of each Compass-485 unit is univocal and included between 0 and 19. Addresses above 19 are not recognised. The presence of two Compass 485 units with the same address causes software conflicts.

NOTE: When communication between the Securbase and Compass-485 units is interrupted due to a failure or software problem, the stand-alone functions of the Compass-485 unit are nevertheless active, which means that the access events can always be controlled and the validity of the cards in the memory be checked. For this to be effective, it is necessary to update the memory of the Compass-485 unit every time activation or deactivation occurs.

For further information, refer to the Securbase Instructions.

9) MALFUNCTION: CAUSES AND REMEDIES

a) The POW Led is off:

Check if the system is being supplied with power.

b) The reader does not recognise the card:

Make sure that the type of card is correct and that it is enabled.

Check for the presence of power supply (POW Led on) and that the system is wired and configured correctly.

10) MAINTENANCE AND SCRAPPING

Maintenance operations on the system must be carried out by qualified personnel only. Dispose of the materials making up the system and its packing according to the relevant laws in force.

WARNINGS

Trouble-free operation of the system is only guaranteed when the data contained in this manual is adhered to.

The manufacturer cannot be held responsible for any damage caused by failure to observe the installation standards and directives specified in the present manual.

The descriptions and illustrations contained in the present manual are not binding. The Company reserves the right to make any alterations deemed appropriate for the technical, manufacturing and commercial improvement of the product, while leaving the essential product features unchanged, at any time and without undertaking to update the present publication.

Fig. 1

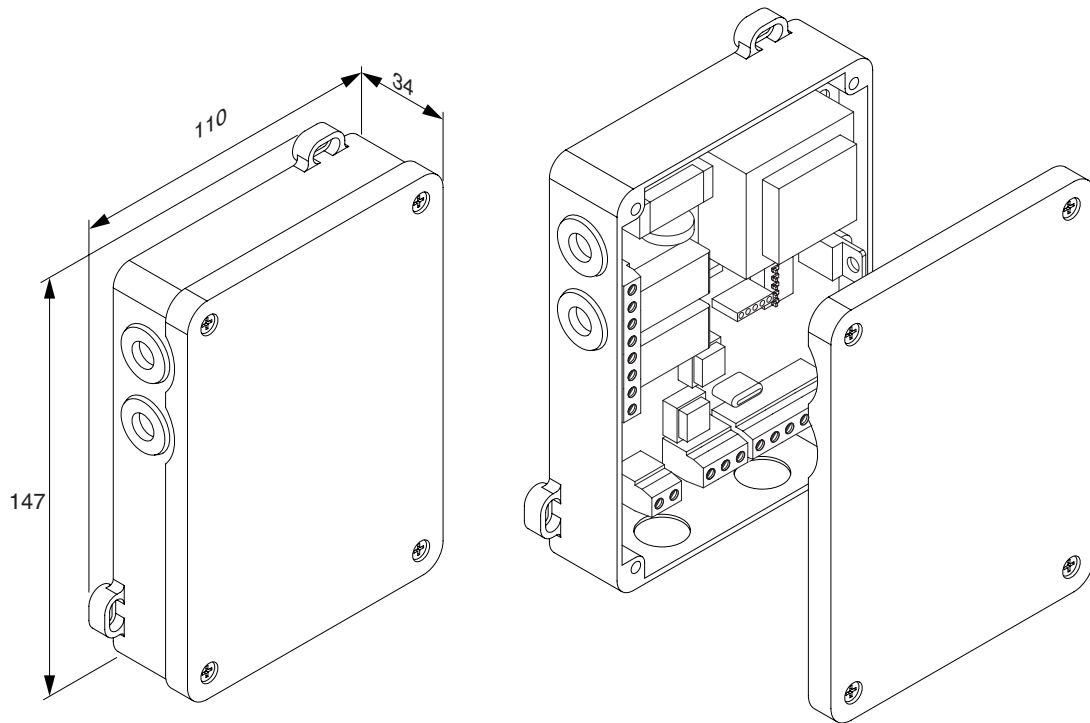

Fig. 2

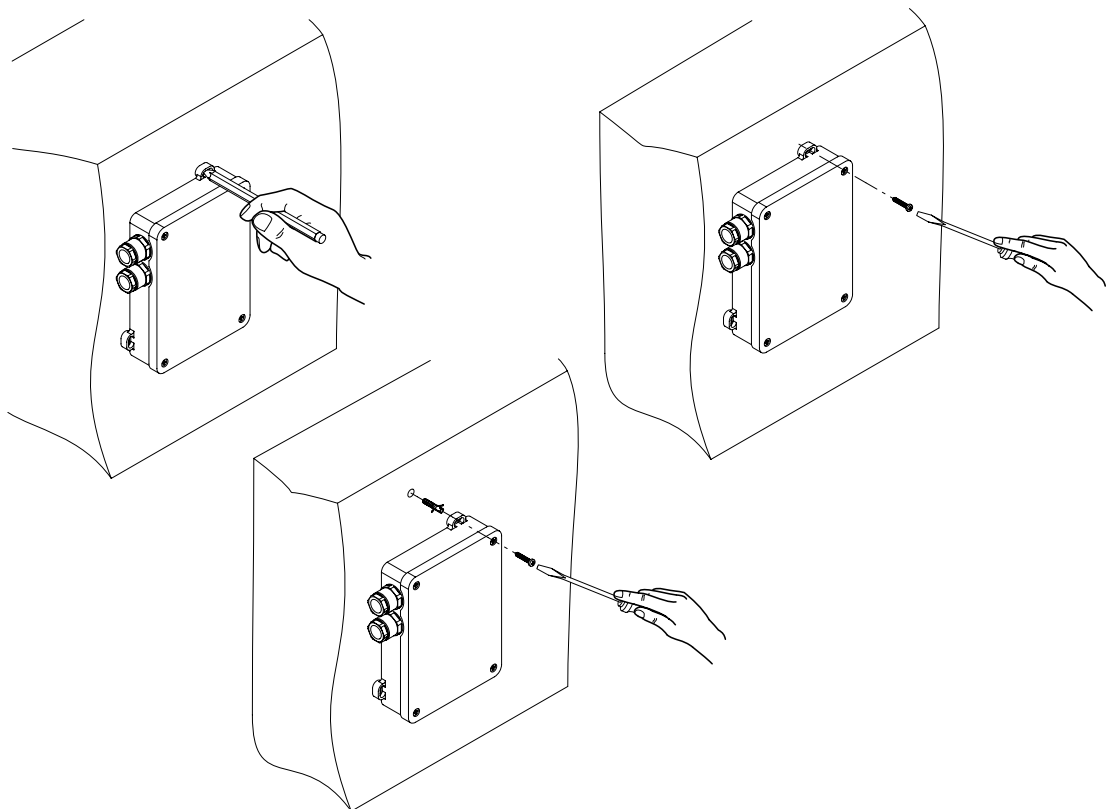
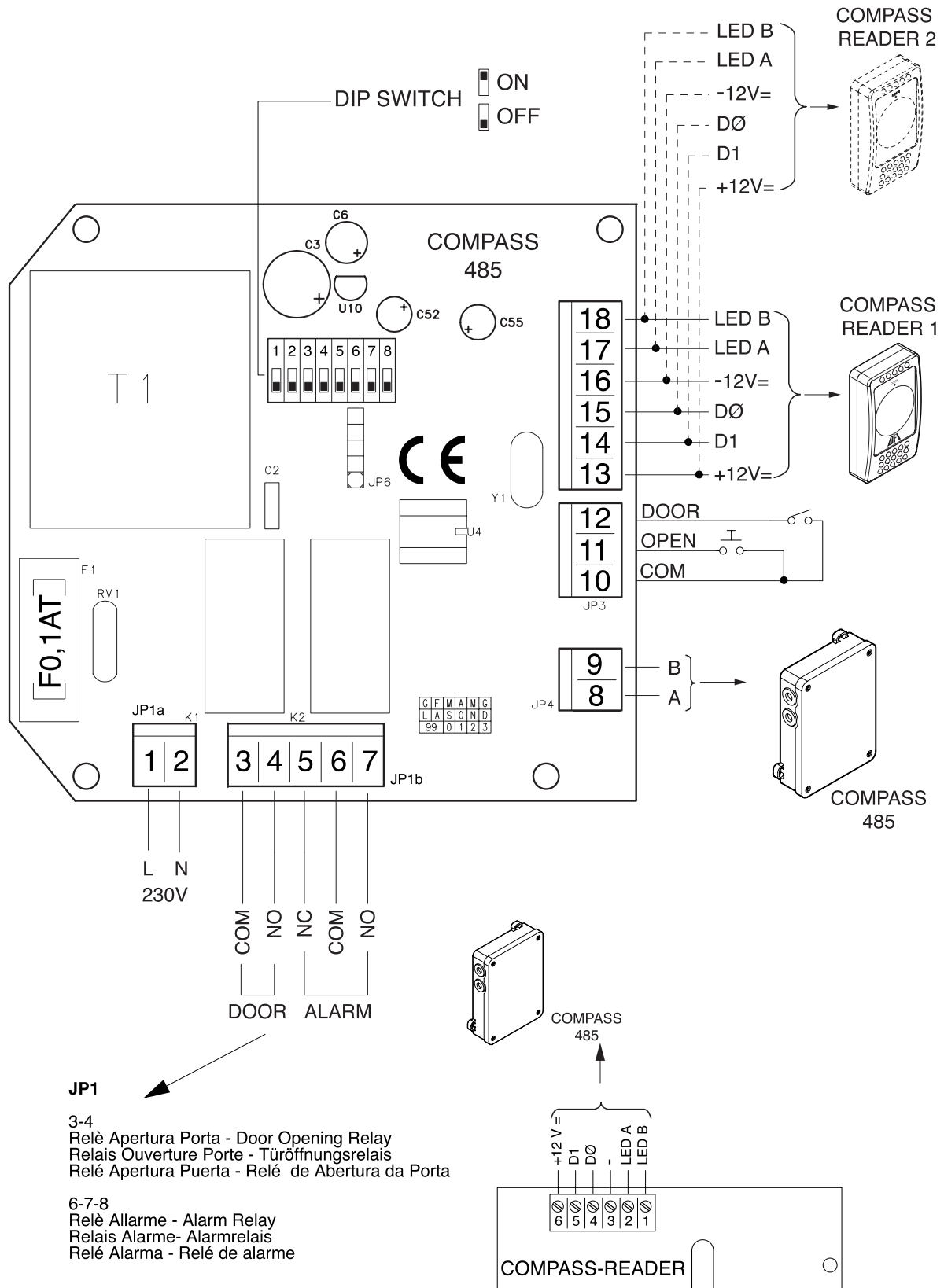

Fig. 3



COMPASS 485/232

Fig. 4

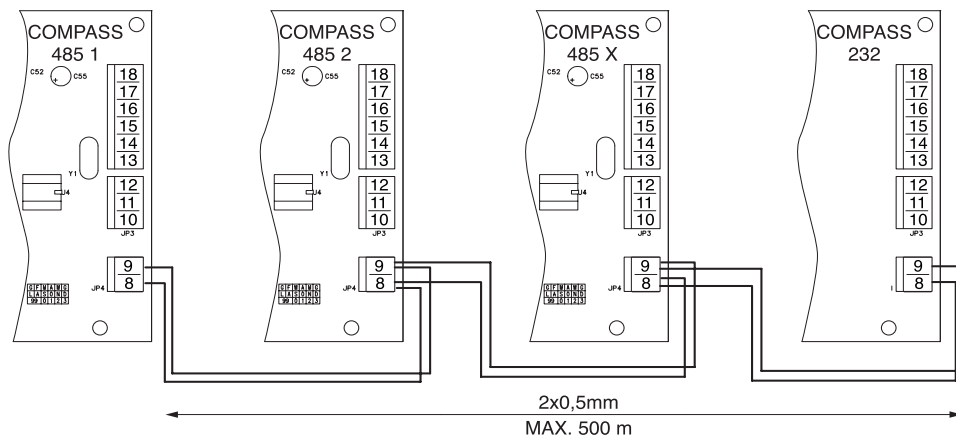
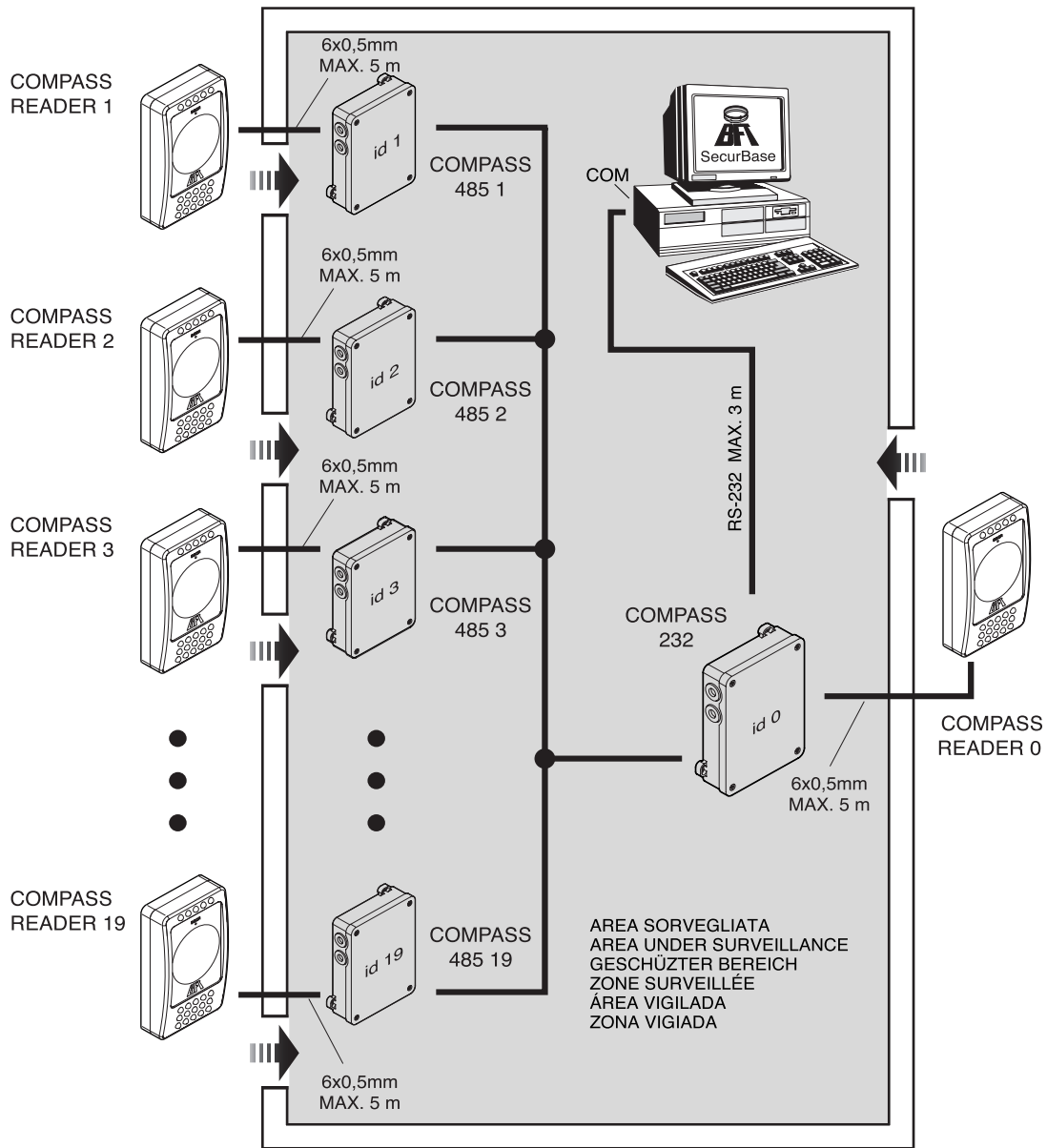

Fig. 5

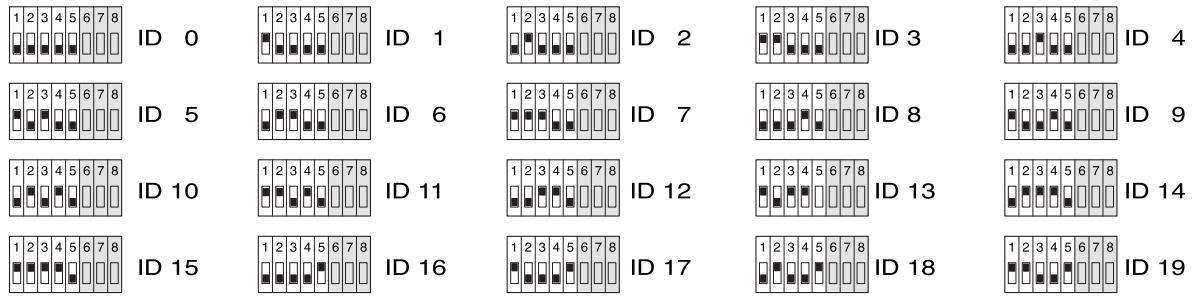

Fig. 6

