

ROCK

DEA[®]
move as you like

-ROCK

-ROCK/CABLE

- IT **Dissuasore di traffico oleodinamico**
Istruzioni d'uso ed avvertenze
- EN **Hydraulic traffic bollard**
Operating instructions and warnings
- FR **Limiteur de circulation oléohydraulique**
Notice d'emploi et avertissements
- DE **Hydraulischer Straßen Poller**
Bedienungsanleitung und Hinweise
- ES **Disuasor de tráfico oleodinámico**
Instrucciones de uso y advertencias
- PT **Dissuasor de tráfico hidráulico**
Instruções para utilização e advertências
- PL **Hydrauliczny słupek blokady wjazdu**
Instrukcja montażu i użytkowania
- RU **Гидравлический блокиратор движения**
Инструкции и предупреждения

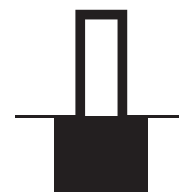

www.deasystem.com

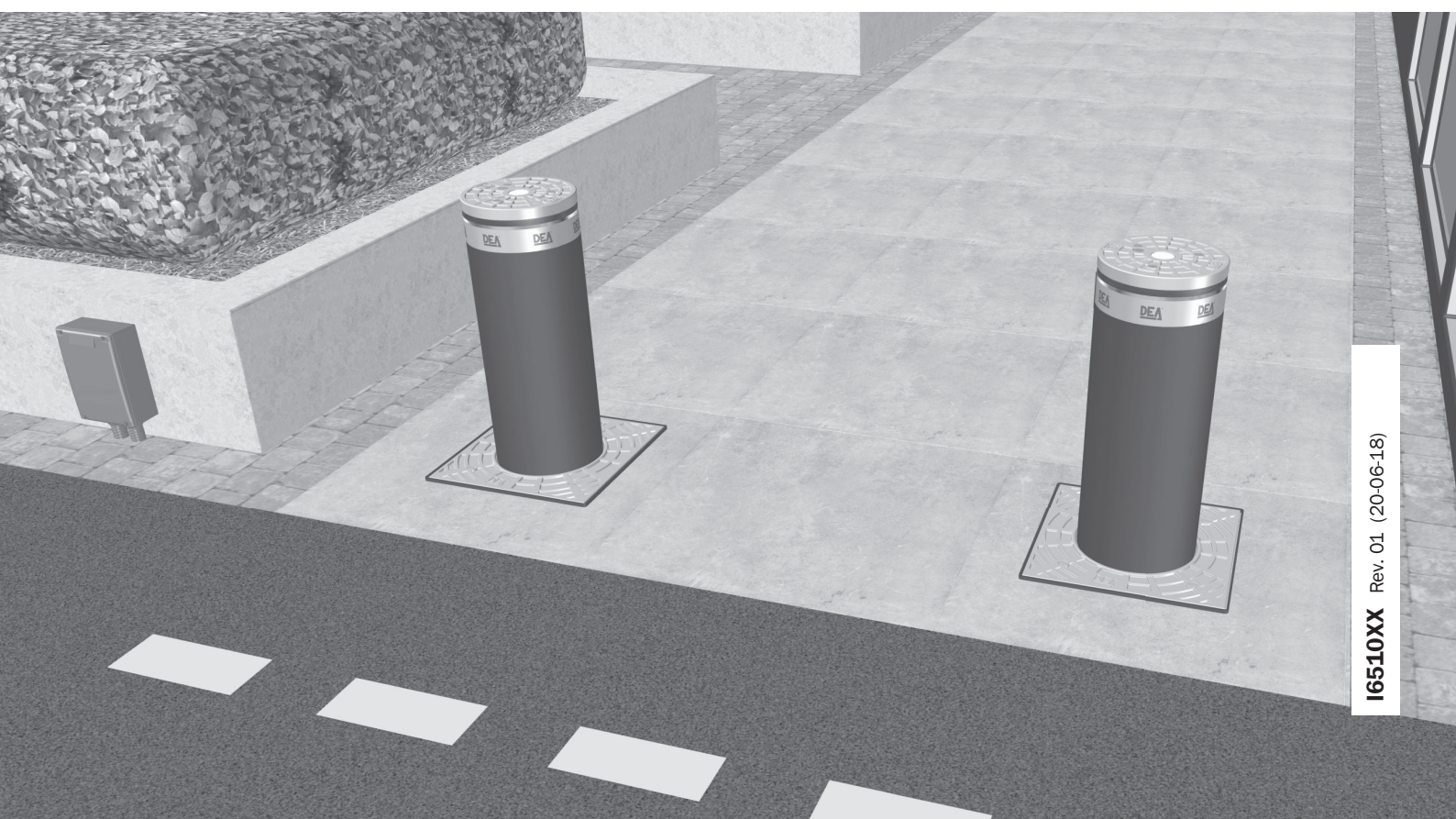

ROCK

Hydraulic traffic bollard

Operating instructions and warnings

Index

1	Warnings Summary	EN-1	6	Start-up	EN-7
2	Product Description	EN-3	6.1	Installation Test	EN-7
3	Technical data	EN-3	6.2	Unlocking and manual operation	EN-7
4	Installation and Assembly	EN-4	7	Maintenance	EN-8
5	Electrical Connections	EN-7	8	Product Disposal	EN-8

1 WARNINGS SUMMARY

WARNING! IMPORTANT SAFETY INSTRUCTIONS. CAREFULLY READ AND FOLLOW ALL WARNINGS AND INSTRUCTIONS THAT ACCOMPANY THE PRODUCT SINCE INCORRECT INSTALLATION COULD CAUSE HARM TO PEOPLE, ANIMALS OR THINGS. WARNINGS AND INSTRUCTIONS PROVIDE IMPORTANT INFORMATION REGARDING SAFETY, INSTALLATION, USE AND MAINTENANCE. KEEP THE INSTRUCTIONS TOGETHER THE TECHNICAL DOCUMENTATION AND FOR FUTURE REFERENCE.

⚠ **WARNING** The device may be used by children of less than 8 years of age, people with reduced physical, mental or sensory impairment, or generally anyone without experience or, in any case, the required experience provided the device is used under surveillance or that users have received proper training on safe use of the device and are aware of the dangers related to its use.

⚠ **WARNING** Do not allow children to play with the device, the fixed commands or the radio controls of the system.

⚠ **WARNING** Product use in abnormal conditions not foreseen by the manufacturer may generate hazardous situations; meet the conditions indicated in these instructions.

⚠ **WARNING DEA** System reminds all users that the selection, positioning and installation of all materials and devices which make up the complete automation system, must comply with the European Directives 2006/42/CE (Machinery Directive), 2014/53/UE (RED Directive). In order to ensure a suitable level of safety, besides complying with local regulations, it is advisable to comply also with the above mentioned Directives in all extra European countries.

⚠ **WARNING** Under no circumstances use the device in an explosive atmosphere or in areas that may be corrosive or could damage product parts. Check that the temperatures at the installation site are suitable and comply with the temperatures declared on the product label.

⚠ **WARNING** When working with the “dead man” switch, make sure that there are no people in the area where the automatism is being used.

⚠ **WARNING** Check that there is a switch or an omni polar magneto-thermal circuit breaker that enables complete disconnection in case of over voltage category III conditions installed upstream from the power system.

⚠ **WARNING** To ensure an appropriate level of electrical safety always keep the 230V power supply cables apart (minimum 4mm in the open or 1 mm through insulation) from low voltage cables (motors power supply, controls, electric locks, aerial and auxiliary circuits power supply), and fasten the latter with appropriate clamps near the terminal boards.

⚠ **WARNING** If the power cable is damaged, it must be replaced by the manufacturer or its technical assistance service or, in any case, by a person with similar qualifications to prevent any risk.

⚠ **WARNING** All installation, maintenance, cleaning or repair operations on any part of the system must be performed exclusively by qualified personnel with the power supply disconnected working in strict compliance with the electrical standards and regulations in force in the nation of installation.

Cleaning and maintenance destined to be performed by the user must not be performed by unsupervised children.

⚠ **WARNING** Using spare parts not indicated by **DEA** System and/or incorrect re-assembly can create risk to people, animals and property and also damage the product. For this reason, always use only the parts indicated by **DEA** System and scrupulously follow all assembly instructions.

⚠ **WARNING** The compliance of the internal sensing obstacles device to requirements of EN12453 is guaranteed only if used in conjunction with motors fitted with encoders.

⚠ **WARNING** Any external security devices used for compliance with the limits of impact forces must be conform to standard EN12978.

 **WARNING** In compliance with EU Directive 2012/19/EU on waste electrical and electronic equipment (WEEE), this electrical product should not be treated as municipal mixed waste. Please dispose of the product and bring it to the collection for an appropriate local municipal recycling.

EVERYTHING THAT IS NOT EXPRESSLY PROVIDED FOR IN THE INSTALLATION MANUAL IS NOT ALLOWED. CORRECT OPERATOR OPERATION IS ONLY ENSUED WHEN THE REPORTED DATA IS RESPECTED. THE COMPANY DOES NOT RESPOND FOR DAMAGE CAUSED BY FAILURE TO COMPLY WITH THE INSTRUCTIONS CONTAINED IN THIS MANUAL. WITHOUT AFFECTING THE ESSENTIAL FEATURES OF THE PRODUCT, THE COMPANY RESERVES THE RIGHT TO MAKE ANY CHANGES DEEMED APPROPRIATE AND AT ANY TIME IN ORDER TO TECHNICALLY, STRUCTURALLY AND COMMERCIALY IMPROVE THE PRODUCT WITHOUT BEING REQUIRED TO UPDATE THIS DOCUMENT.

2 PRODUCT DESCRIPTION

2.1 Description

A family of automatic hydraulic traffic bollards is identified with the name ROCK. The cylinder is driven by a hydraulic unit positioned inside the same. The bollard has a manual safety release device which, if activated, allows the cylinder to be lowered, thus leaving the passage free in the case of emergencies and/or mains power failure.

The automatic lowering of the hydraulic unit, can only take place with the accessory solenoid valve (art. ROCK/EL not supplied) installed; in this case, the type of release can be selected by operating directly on the solenoid valve and activate, or not, the automatic lowering of the cylinder in the event of power failure.

The accompanying accessories are shown in the "PRODUCT ACCESSORIES" table (page I-9).

2.2 Content of the packaging

All the material is accurately controlled and inspected by the manufacturer before shipping.

On receipt of the bollard, make sure that it has not undergone damage during transport and that nothing has been tampered with or removed. If damage or missing parts are detected, immediately inform the carrier and the manufacturer, and produce photographic documentation. On receipt, during unpacking, dispose of the packaging components with reference to National Disposal Laws regarding solid waste.

2.3 Lifting and Transport

Suitable equipment must be used to lift and transport the bollard, with respect to work place safety regulations in force in the area of installation of the product.

The eye-bolts and the ropes must have capacity higher than the weight to be lifted, be in good working order and must have CE marking and respective certification in force.

WARNING For transport of the bollard, vehicles are requires with minimum capacity higher than the weight declared for the same (the weight of the bollard is given on the identification plate). Before beginning handling, check the efficiency of the lifting devices and their capacity. During bollard lifting and handling operations, all possible precautions must be taken in order to prevent hazardous movements, which could cause accidents or damage to the persons and/or materials and objects. Avoid sudden movements, which could lead to damage to the bollard.

The bollard must be handled by expert personnel.

3 TECHNICAL DATA

	ROCK	ROCK/CABLE
Handling	Hydraulics	
Rod out of the ground	700 mm	
Cylinder diameter	275 mm	
Standard cylinder material	Fe 360 steel	
Cylinder treatment	Cathaphoresis and black polyester powder paint	
Ascent time	~ 6 sec	
Descent time (standard)	~ 5 sec	
Rapid descent time (via solenoid valve and power supply failure)	~ 1,5 sec	
Max. N°. manoeuvres in 24 hours	300 (with art. ROCK/EL solenoid valve) 2000 (without solenoid valve *considering a temperature of 20÷22 °C)	
Retro-reflective strip	50 mm	
Manual lowering manoeuvre	Mechanical release on hydraulic circuit	
Shock resistance	29 kJ with anchor bolts - 40 kJ with additional reinforcement	
Resistance to breakthrough	29 kJ with anchor bolts - 138 kJ with additional reinforcement	
Connection cable	/	15 m 7Gx1,5 + 10x0,5
	Warning: In order to prevent operating problems inside the plant, the connection cables must have maximum length of 80 metres. Any cable joints must be made perfectly and inside junction boxes.	
Operating temperature	-15 ÷ 50 °C -25 ÷ 50 °C (with art. ROCK/RE heater)	
Anti-rising safety device	Adjustable with pressure switch	
Product weight	130 kg	
Power supply voltage	230 V ~ ±10% (50/60 Hz)	
Absorption	400 W	
Protection rating	IP 67	
Condenser	12,5 µF	
Motor thermal monitoring	130 °C	

4 INSTALLATION AND ASSEMBLY

WARNING The laying, installation/wiring procedure described below must **NOT** be performed by the end user or **NON-specialised** personnel.

CRUSHING HAZARD During bollard installation operations all possible precautions must be taken to prevent movements that could cause damage to objects and/or persons.

WARNING All images shown in this manual are for guidance only, so that the descriptions can be understood immediately.

4.1 Set-ups

- Make sure that the place the bollard is positioned is not in a water collection area; where this situation should occur, the bollard must be partly shielded by surrounding it with a draining channel with covering grid.
- The consistency of the ground must **NOT** be friable. If friable, envision a larger hole in the ground to stabilise the bollard, in order to prevent the plinth escaping from the concrete after a blow.

WARNING These decisions **MUST** be assessed and implemented by qualified personnel.

4.2 Excavation (Fig. 2)

Assess the level of shock resistance desired and proceed with excavation:

Fixing via additional reinforcement

Excavate to a depth of approx. 155 cm.

The excavation must have dimensions of 140x190 cm.

Fixing via anchor bolts

Excavate to a depth of approx. 155 cm.

The excavation must have dimensions of 90x125 cm.

WARNING Pay attention to the direction of travel as indicated in Fig. 3.

4.3 Connection to sewer system

Make sure that the land has good draining capacity by introducing approx. 40 litres of water and checking emptying takes place in less than 30 minutes. **If this is not the case, drain the waters via piping to be connected to each individual formwork** (pipe diameter 80 mm) and connected to the sewer system with siphon, or to a pit with a water emptying system.

4.4 Cementing via additional reinforcement

- Introduce gravel (grain with diameter of approx. 22/32 mm) with thickness of approx. 30 cm, making sure it is compacted well to prevent future "settling withdrawals".
- Lay the layer of geotextile (300 g.) on the compacted gravel.
- Position a PVC pipe with diameter of 200 mm and length of 220 mm in the centre of the hole and **ABOVE** the geotextile (the PVC pipe is necessary to channel the rain water).
- Introduce concrete (RCK45 type) into the hole to a height of 200 mm, making sure that the pipe remains in the centre and escapes by at least 20 mm.

Warning: the concrete casting must be level (check that the concrete base is level with the ground in order to obtain a good support for the bollard).

Warning: make sure that the height from the base of the cementing just performed is 1000 mm at the road surface (Fig. 4c).

- Assemble the reinforcement cage as indicated in Fig. 6 (n° 36 bars Ø8 and n° 5 horizontal brackets to be fixed in an equidistant way, using the classical metal wire for reinforcement).
- Place the cage inside the excavation, making sure it is true and plumb.
- Assemble the metal pit (Fig. 5) using the rivets supplied and fix it to the secondary frame using the relative bolts supplied.
- Place the metal pit complete with secondary frame, making sure it is plumb. The upper level of the secondary frame must be positioned 20 mm higher with respect to ground height (to limit the entry of rain water into the pit).

Warning: make sure that the metal pit is positioned correctly with respect to the direction of travel.

- Assemble n° 11 anchor bolts in Ø12 B450C steel bars as indicated in Fig. 3; make sure that improved adhesion steel bars are used.
- Position the flexible hose with diameter of 45 mm (for passage of the power supply and command cables) in the relevant pilot holes of the formwork. The piping must be connected to the plant management and handling station.
- Introduce concrete (RCK4 type) all around the metal pit up to ground level and successively connect the projecting part to the road surface.

Warning: make sure that the concrete casting is vibrated using suitable equipment in away to adhere correctly to the walls of the metal pit and that the same remains above the ground level by at least 20 mm (Fig. 7).

WARNING All piping must be positioned with full respect of regulations in force.

4.5 Cementing via anchor bolts

- Introduce gravel (grain with diameter of approx. 22/32 mm) with thickness of approx. 30 cm, making sure it is compacted well to prevent future “settling withdrawals”.
- Lay the layer of geotextile (300 g.) on the compacted gravel.
- Position a PVC pipe with diameter of 200 mm and length of 220 mm in the centre of the hole and **ABOVE** the geotextile (the PVC pipe is necessary to channel the rain water).
- Introduce concrete (RCK45 type) into the hole to a height of 200 mm, making sure that the pipe remains in the centre and escapes by at least 20 mm.

Warning: the concrete casting must be level (check that the concrete base is level with the ground in order to obtain a good support for the bollard).

Warning: make sure that the height from the base of the cementing just performed is 1000 mm at the road surface (Fig. 4c).

- Assemble the metal pit (Fig. 5) using the rivets supplied and fix it to the secondary frame using the relative bolts supplied.
- Place the metal pit complete with secondary frame, making sure it is plumb. The upper level of the secondary frame must be positioned 20 mm higher with respect to ground height (to limit the entry of rain water into the pit).

Warning: make sure that the metal pit is positioned correctly with respect to the direction of travel.

- Position the flexible hose with diameter of 45 mm (for passage of the power supply and command cables) in the relevant pilot holes of the formwork. The piping must be connected to the plant management and handling station.
- Introduce concrete (RCK4 type) all around the metal pit up to ground level and successively connect the projecting part to the road surface.

Warning: make sure that the concrete casting is vibrated using suitable equipment in away to adhere correctly to the walls of the metal pit and that the same remains above the ground level by at least 20 mm (Fig. 7).

WARNING All piping must be positioned with full respect of regulations in force.

4.6 Laying the traffic bollard (Fig. 8)

- Remove the cable cross platform from the structure by removing the protection caps and loosening the 4 underlying screws.
- Tighten 2 x M12 eye-bolts as indicated and lower the structure into the pit.

Warning: on lowering the structure, pay maximum attention not to pinch the power supply cable and to the position of the electrical box.

- Remove the eye-bolts and fix the structure tightly to the metal pit structure using the 8 countersunk head screws provided.
- Re-position the cable cross platform in its seat and fix it with the screws (and protection caps), which were previously removed (Fig. 9).

4.7 Release and manual movement (Fig. 10)

In the event of mains power failure, the bollard remains raised and the release device must be operated to lower it.

Operate as follows to do this:

- Unscrew the closure cap positioned on the head of the bollard.
- Insert the relevant key supplied, loosen anti-clockwise by approx. 1 turn and wait for the bollard to descend completely.
- To take the bollard back to working condition, turn the key clockwise.

WARNING Remember to tighten the cap on completion of the manual handling operations, so that the release device is always protected from water and dust.

WARNING The bollard may have uncontrolled movements during the release operation: pay maximum attention in order to prevent every possible risk.

WIRING DIAGRAM ROCK



ATTENTION The total absorption of the integrated standard components supplied with 24V is **~100mA** (limit switch, LED head, buzzer).

ATTENTION For the wiring of 2 bollards to a single control unit NET230N, it will be **necessary** to provide a separate power source for any 24V accessories that should normally be connected to the +24VAUX and +24_ST outputs (photo-cells, radio receivers, etc.).

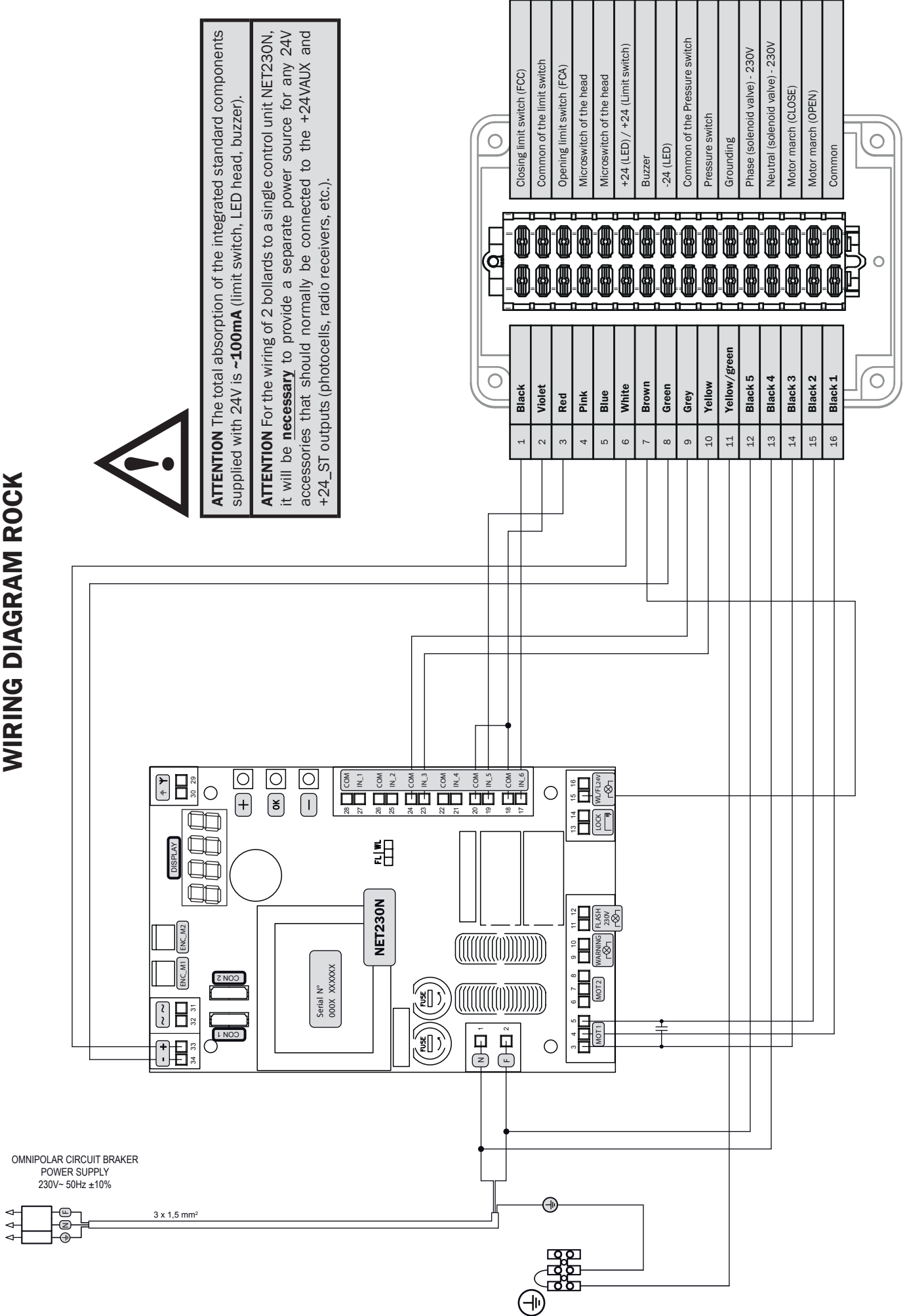

5 ELECTRICAL CONNECTIONS

Run the motor connections following the wiring diagrams.

WARNING For adequate electrical safety, keep low safety voltage wires (controls, electro-locks, antenna, auxiliary power) clearly separate from 230V ~ power wires (**minimum 4 mm in air or 1 mm via supplementary insulation**) placing them in plastic raceways and securing them with adequate clamps near terminal boards.

WARNING For connection to the mains, use a multipolar cable having a minimum section 3x1,5 mm² and complying with the current regulations. For connecting the motors, use a minimum cross section 1,5 mm² cable and complying with the current regulations. As an example, if the cable is out side (outdoor), must be at least equal to H05RN-F, whereas if it (in a raceway), must be at least equal to H05VV-F.

WARNING All wires must be striped and unsheathed in the immediate vicinity of terminals. Keep wires slightly longer to subsequently eliminate any excess.

WARNING Maintain the ground conductor at a major length respect the active conductors so that, if the cable exit from its fixing housing, the active conductors tighten up as first.

WARNING In the ROCK versions without a cable, separate wiring must be provided for the motor supply (FG 16x1,5mmq) and the controls (FG 10x0,5mmq).

After connection, it is advisable to seal the wiring box with contact sealant (e.g. Etelec Replaygel).

Program the control board to complete all adjustments. It is now possible to supply a complete installation in compliance with all standards required for gate automation. **See the instructions provided with the control panel to be connected.**

WARNING If the system foresees the installation of 2 bollards, for the wiring of the completion accessories, it will be necessary to integrate an input expansion card art. NET-EXP.

Finally, verify that all adjustments operations have been correctly performed and that safety devices and unlocking device properly work.

6 COMMISSIONING

The commissioning phase is extremely important for ensuring maximum system safety, as well as legal and regulatory compliance, namely with all the requirements of EN 12445, which establishes the test methods of the plants.

DEA System would like to emphasize that any system installation, cleaning or repair operations must only be carried out by qualified personnel, who must conduct all the tests necessary based on the risks present;

6.1 Inspecting the plant

Inspection is essential to check correct system installation. **DEA** System summarises the correct inspection of all automation in 4 simple steps:

- Make sure that described in paragraph 2 "SUMMARY OF WARNINGS" is strictly observed;
- Carry out the bollard raising and lowering tests tests, checking that the movement corresponds with that envisioned. To this regard, we recommend you run several trials to identify any assembly or adjustment defects;
- Make sure all safety devices connected to the system operate correctly;

WARNING The use of spare parts not indicated by **DEA** System and/or incorrect assembly may cause hazardous situations to people, animals and property; they may also cause product malfunctions; always use the parts indicated by **DEA** System and scrupulously follow the assembly instructions.

6.2 Release and manual manoeuvre

In the case of plant anomalies or simple power failure, perform the manual emergency manoeuvre and lower the bollard (Fig. 10). Know-how regarding operation of the release device is very important, since in times of emergencies slow action in operating this device can cause hazardous situations.

WARNING The safety and efficacy of moving the automation manually is only guaranteed by **DEA** System if the system has been properly installed using original accessories.

7 MAINTENANCE

Good preventive maintenance and regular inspection ensure long working life. In the table below you will find a list of inspections/maintenance operations to be programmed and executed periodically.

Consult the "TROUBLE-SHOOTING" table whenever anomalies are observed in order to find the solution to the problem and contact **DEA** System directly whenever the solution required is not provided.

TYPE OF INTERVENTION	PERIODICITY
Clean external surfaces	6 months
Check status of wear of the retro-reflective tape on the rod	6 months
Check status of luminous indicators	6 months
Check functioning of release device	6 months
Check operation of the command unit and the safety devices	6 months

TROUBLESHOOTING	
Description	Possible solutions
The bollard rises for a few centimetres and lowers immediately.	Check correct wiring of the safety pressure switch.
	Check correct adjustment of the pressure switch.
	Replace the pressure switch.
As soon as the bollard reaches the high position, it inverts immediately.	Check correct wiring of limit switch.
	Check the correct adjustment of the high position limit switches.
The bollard does not rise but remains low in opening position.	Check that the bollard is re-blocked hydraulically (after an eventual emergency manual release Fig. 10).
	Check correct operation of the solenoid valve (art. ROCK/EL not supplied) and replace the component if necessary.
The bollard does not lower but remains low in closing position.	Check that there are no obstructions between the sliding ring and the cylinder. Try to shake the cylinder to facilitate descent.
The luminous and acoustic indicators do not work.	Check the correct wiring of the power supply connector positioned under the cylinder head.
	Replace the circuit.

8 PRODUCT DISPOSAL

ROCK consists of materials of various types, some of which can be recycled (electrical cables, plastic, aluminum, etc. ...) while others must be disposed of (electronic boards and components).

Proceed as follows:

1. Disconnect the power supply;
2. Disconnect and disassemble all the accessories connected. Follow the instructions in reverse to that described in the section "Installation";
3. Remove the electronic components;
4. Sorting and disposing of the materials exactly as per the regulations in the country of sale.



WARNING In line with EU Directive 2012/19/EU for waste electrical and electronic equipment (WEEE), this electrical product must not be disposed of as unsorted municipal waste. Please dispose of this product by returning it to your local municipal collection point for recycling.

Esempio di installazione tipica - Example of typical installation - Exemple d'installation typique - Installationsbeispiel - Ejemplo de instalación típica - Exemplo de instalação típica - Przykład standardowego systemu automatyzacji - Пример типового монтажа

DEA System fornisce queste indicazioni che si possono ritenere valide per un impianto tipo ma che non possono essere complete. Per ogni automatismo, infatti, l'installatore deve valutare attentamente le reali condizioni del posto ed i requisiti dell'installazione in termini di prestazioni e di sicurezza; sarà in base a queste considerazioni che redigerà l'analisi dei rischi e progetterà nel dettaglio l'automatismo. - DEA System provides the following instructions which are valid for a typical system but obviously not complete for every system. For each automatism the installer must carefully evaluate the real conditions existing at the site. The installation requisites in terms of both performance and safety must be based upon such considerations, which will also form the basis for the risk analysis and the detailed design of the automatism. - DEA System fournit ces indications que vous pouvez considérer comme valables pour une installation-type, même si elles ne peuvent pas être complètes. En effet, pour chaque automatisations, l'installateur doit évaluer attentivement les conditions réelles du site et les pré-requis de l'installation au point de vue performances et sécurité; c'est sur la base de ces considérations qu'il rédigera l'analyse des risques et qu'il concevra l'automatisation d'une manière détaillée. - Diese Angaben von DEA System können als gültig für eine Standardanlage angesehen werden, können aber nicht erschöpfend sein. So muss der Installationsfachmann für jedes Automatiksystem sorgfältig die Voraussetzungen des Installationsortes sowie die Leistungs- und Sicherheitsanforderungen an die Installation abwägen; aufgrund dieser Überlegungen muss er die Risikobewertung erstellen und genau das Automatiksystem entwickeln. - DEA System facilita

estas indicaciones que pueden considerarse válidas para una instalación tipo pero que no pueden considerarse completas. El instalador, en efecto, tiene que evaluar atentamente para cada automatismo las reales condiciones del sitio y los requisitos de la instalación por lo que se refiere a prestaciones y seguridad; en función de estas consideraciones redactará el análisis de riesgos y efectuará el proyecto detallado del automatismo. - DEA System fornece estas indicações que podem ser consideradas válidas para o equipamento padrão, mas que podem não ser completas. Para cada automatismo praticamente o técnico de instalação deverá avaliar com atenção as condições reais do sítio e os requisitos da instalação em termos de performance e de segurança; será em função destas considerações que realizará uma análise dos riscos e projectará. - DEA System dostarcza wskazówek, do wykorzystania w typowej instalacji ale nie będą one nigdy kompletne. Dla każdego typu automatyki, instalator musi sam oszacować realne warunki miejsca montażu i wymogi instalacyjne mając na uwadze przepisy dotyczące bezpieczeństwa. Na podstawie zebranych informacji będzie w stanie przeanalizować zagrożenia mogące wystąpić i zaprojektować w szczegółach automatyzację. - DEA System предлагает рекомендации, которые действительны для типовой системы, но, очевидно, не обязательны для каждой конкретной установки. Для каждого конкретного случая установщик должен тщательно оценить реальные условия. Устройства для установки оцениваются с точки зрения производительности и безопасности, которые необходимы для анализа рисков и детального проектирования системы автоматизации.

Pos.	Descrizione - Description - Description - Beschreibung - Descripción - Descrição - Opis - Описание
1	ROCK
2	Selettore a chiave anticasso - Anti lock-picking key switch - Sélecteur à clé anti-intrusion - Einbruchfester Schlüsselschalter - Selector a llave antisabotaje - Interruptor de chave burglar - Przełącznik kluczowy wandaloodporny - Замковый выключатель
3	Radiocomando - Remote-control - Radiocommande - Funksteuerung - Radiocomando - Comando via rádio - Nadajnik - Пульт ДУ
4	Selettore digitale - Radio keypad - Digicode radio - Digitalwahlschalter - Teclado digital radio - Teclado via radio - Bezprzewodowa klawiatura - Радио кодовая панель
5	Semaforo a led 230V - 230V led traffic light - Feux LED 230V - Ampel 230V - Semáforo de señalización 230V - Semáforo de trânsito com luz LED 230V - Sygnalizator świetlny 230V - 230V светодиодный светофор
6	Rilevatore per spira magnetica - Loop detector - Détecteur de boucle magnétique - Induktionsschleifen Dedektor - Detector de masas metálicas - Detector de espiras magnéticas - Detektor magnetyczny metali - Магнитный контурный детектор

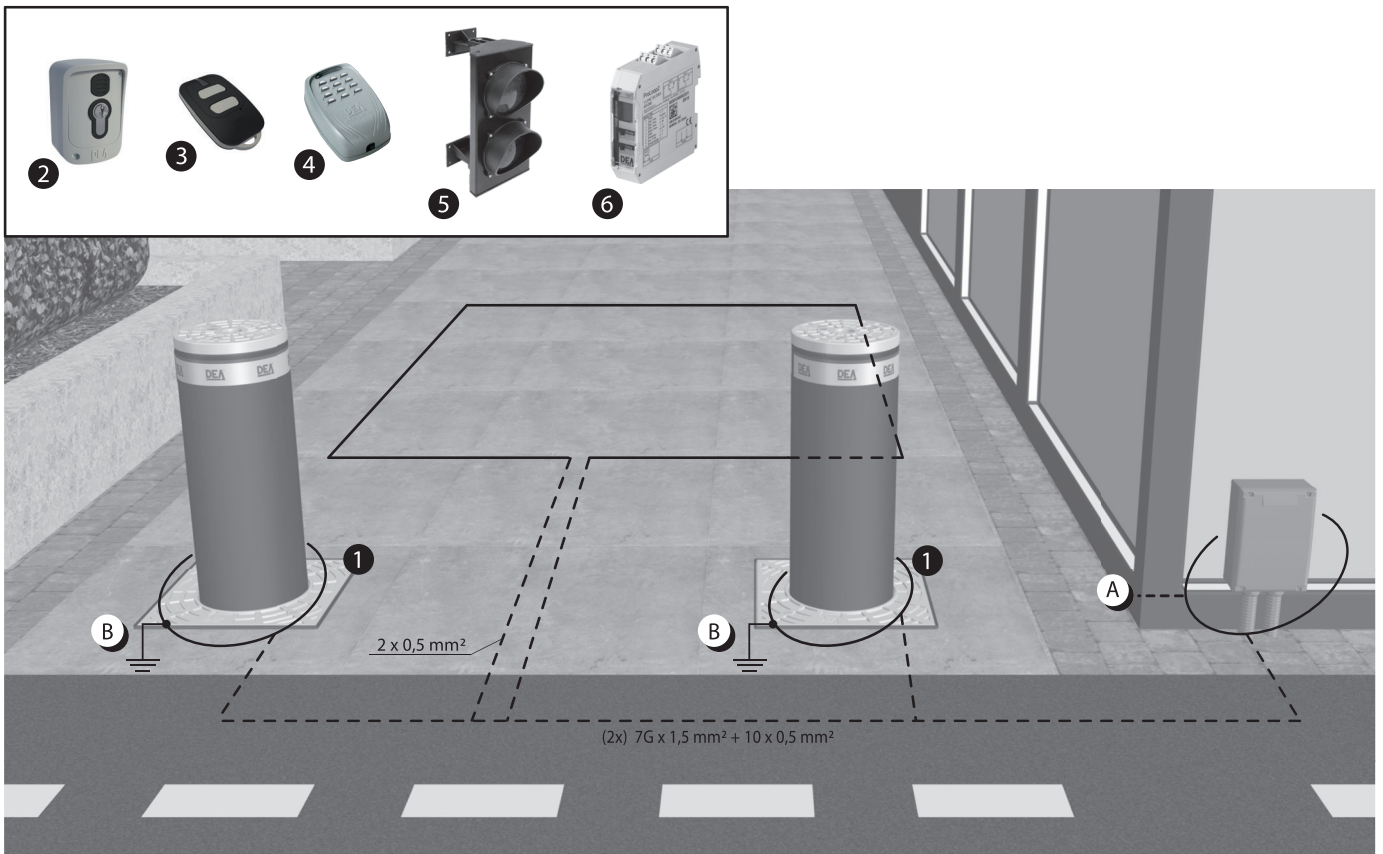

A) Collegarsi alla rete 230 V ± 10% 50-60 Hz tramite un interruttore onnipolare o altro dispositivo che assicuri la onnipolare disinserzione della rete, con una distanza di apertura dei contatti ≥ 3 mm - Make the 230V ± 10% 50-60 Hz mains connection using an omnipolar switch or any other device that guarantees the omnipolar disconnection of the mains network with a contact opening distance of 3 mm - Connectez-vous au réseau 230 V ± 10% 50-60 Hz au moyen d'un interrupteur omnipolaire ou d'un autre dispositif qui assure le débranchement omnipolaire du réseau, avec un écartement des contacts égal à 3 mm. - Den Anschluss an das 230 V ± 10% 50-60 Hz Netz mit einem Allpolschalter oder einer anderen Vorrichtung vornehmen, durch die eine allpolige Netzunterbrechung bei einem Öffnungsabstand der Kontakte von ≥ 3 mm gewährleistet wird. - Efectuar la conexión a una línea eléctrica 230 V ± 10% 50-60 Hz a través de un interruptor omnipolar u otro dispositivo que asegure la omnipolar desconexión de la línea, con 3 mm de distancia de abertura de los contactos. - Ligue na rede de 230 V. ± 10% 50-60 Hz mediante um interruptor omnipolar ou outro dispositivo que assegure que se desliga de maneira omnipolar da rede, com abertura dos contactos de pelo menos 3 mm. de distância - Podłączyć się do sieci 230 V ± 10% 50-60 Hz poprzez przełącznik jednobiegunowy lub inne urządzenie które zapewni brak zakłóceń w sieci, przy odległości między stykami ≥ 3 mm. - Подключайтесь к сети 230V ± 10% 50-60 Гц с помощью многополюсного выключателя или используйте любое другое устройство, которое гарантирует многополюсное отключение питающей сети с расстоянием между контактами от ≥ 3 мм и больше.

B) Collegare a terra tutte le masse metalliche - All metal parts must be grounded - Connectez toutes les masses métalliques à la terre - Alle Metallteile erden - Conectar con la tierra todas las masas metálicas - Realize ligação à terra de todas as massas metálicas - Uziemić wszystkie elementy metalowe. - Все металлические части должны быть заземлены.

1

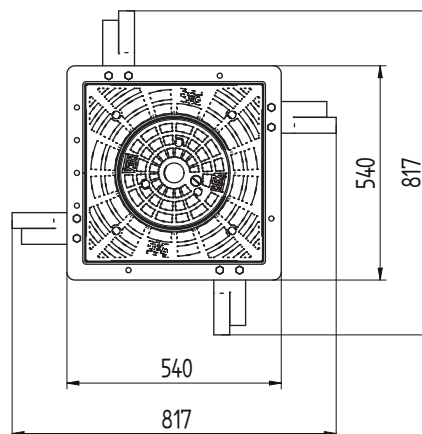
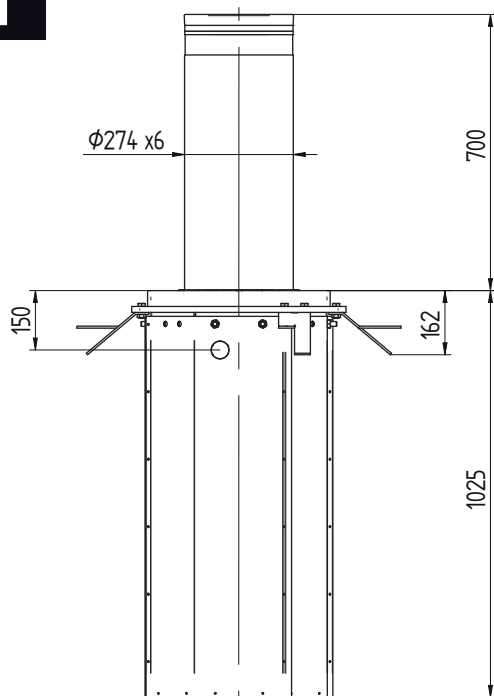

2

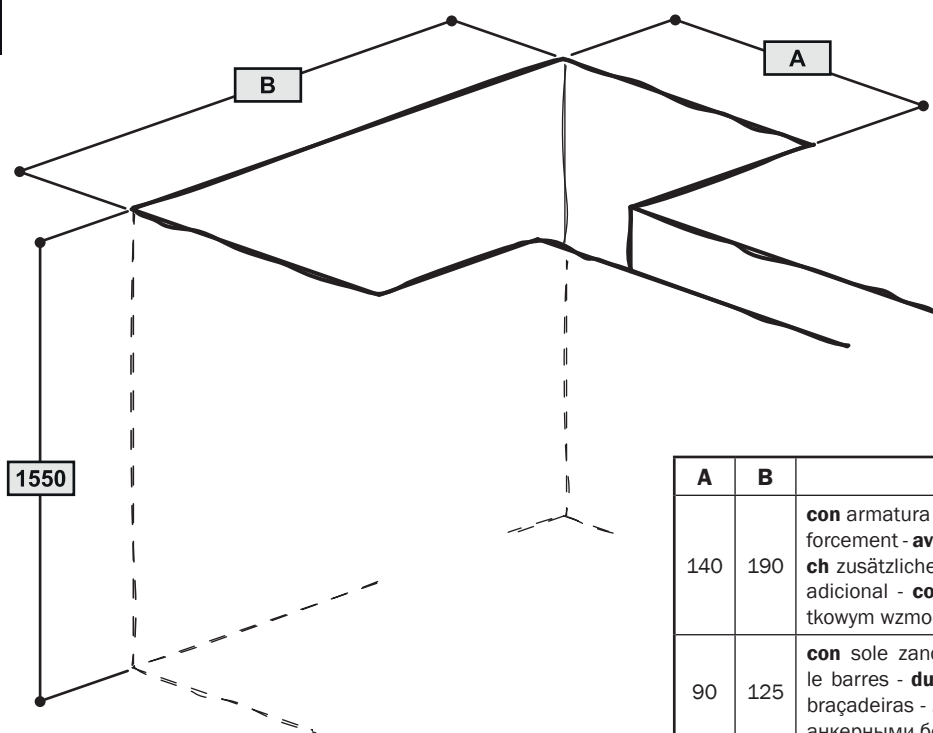

A	B	
140	190	con armatura di rinforzo - with additional reinforcement - avec l'armature additionnelle - durch zusätzliche Armierungseisen - con soporte adicional - com armação adicional - z dodatkowym wzmocnieniem - с армированием
90	125	con sole zanche - with anchor bolts - avec le barres - durch Krallen - con grapas - com braçadeiras - ze śrubami fundamentowymi - с анкерными болтами

Assicurarsi che il terreno abbia una buona capacità drenante immettendo circa 40 litri d'acqua e verificando che lo svuotamento avvenga in meno di 30 minuti; **Make** sure that the land has good draining capacity by introducing approx. 40 litres of water and checking emptying takes place in less than 30 minutes; **S'assurer** que le terrain possède une bonne capacité drainante en introduisant environ 40 litres d'eau et en vérifiant que le vidage ait lieu en moins de 30 minutes; **Stellen** Sie sicher, dass der Boden eine gute Drainagekapazität hat, indem Sie ca. 40 Liter Wasser einfüllen und überprüfen, ob das Wasser in weniger als 30 Minuten abläuft; **Asegúrese** de que el terreno tenga una buena capacidad drenante introduciendo uno 40 litros de agua y comprobando que el vaciado se realice en menos de 30 minutos; **Certificar-se** que o solo tenha uma boa capacidade drenante introduzindo cerca de 40 litros de água e verificando que o esvaziamento aconteça em menos de 30 minutos; **Upewnić** się, że grunt ma dobrą zdolność odprowadzania wody, wstrzykując około 40 litrów wody i sprawdzając, czy opróżnianie odbywa się w czasie krótszym niż 30 minut; **Убедиться** в том, что земля обладает хорошей дренажной способностью, поглощая около 40 литров воды, и контролируя, что впитывание происходило в течение, по крайней мере, 30 минут.

3

Con sole zanche - With anchor bolts - Avec le barres - Durch Krallen - Con grapas - Com braçadeiras - Ze śrubami fundamentowymi - С анкерными болтами

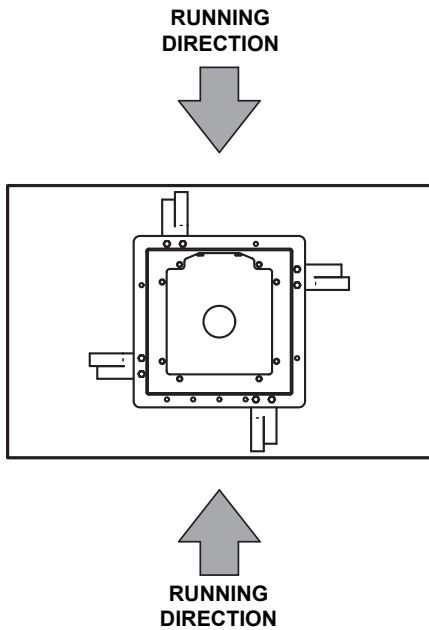

Con armatura di rinforzo - With additional reinforcement - Avec l'armature additionnelle - Durch zusätzliche Armierungseisen - Con soporte adicional - Com armação adicional - Z dodatkowym wzmocnieniem - С армированием

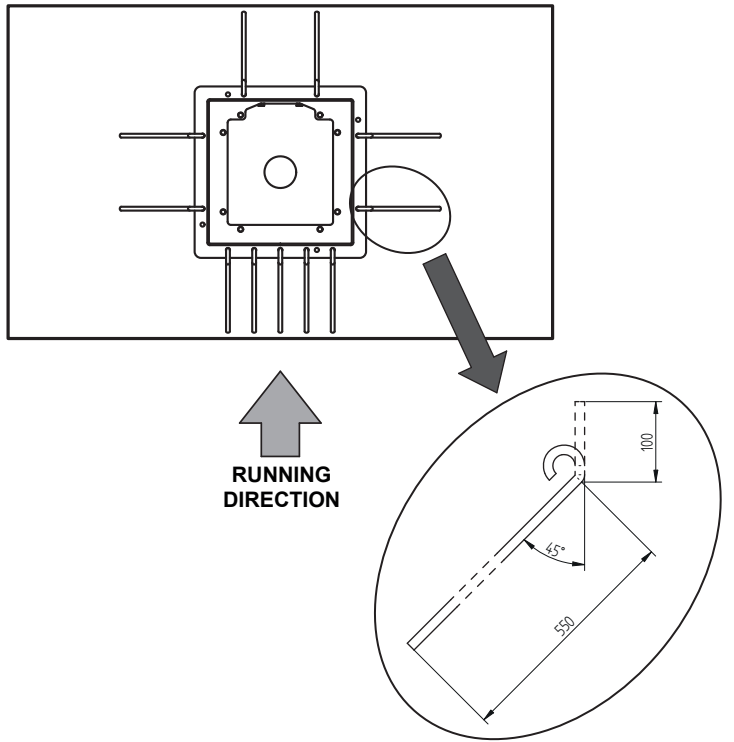

4a

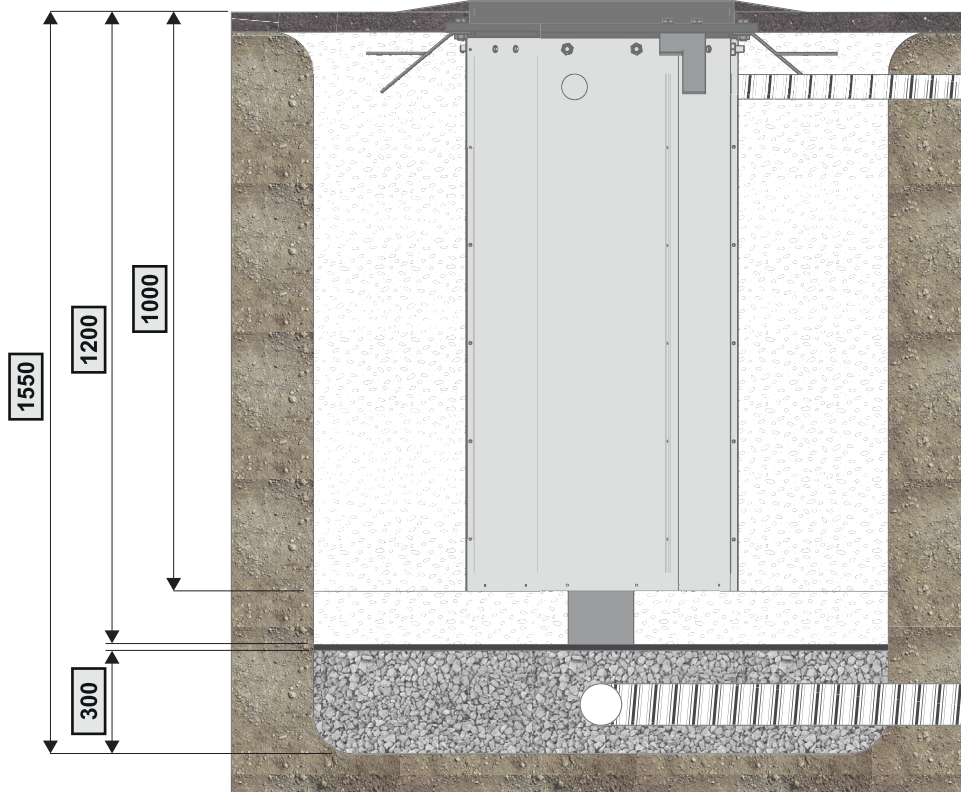

4b

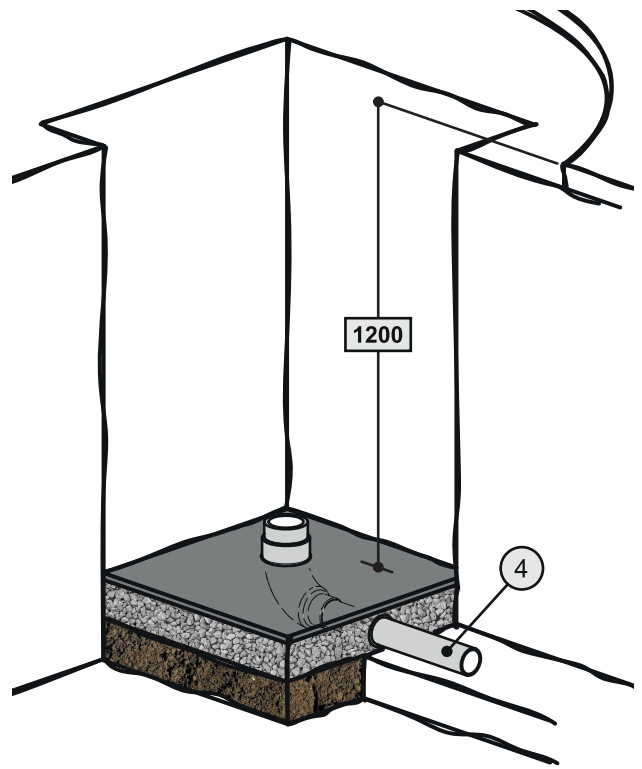
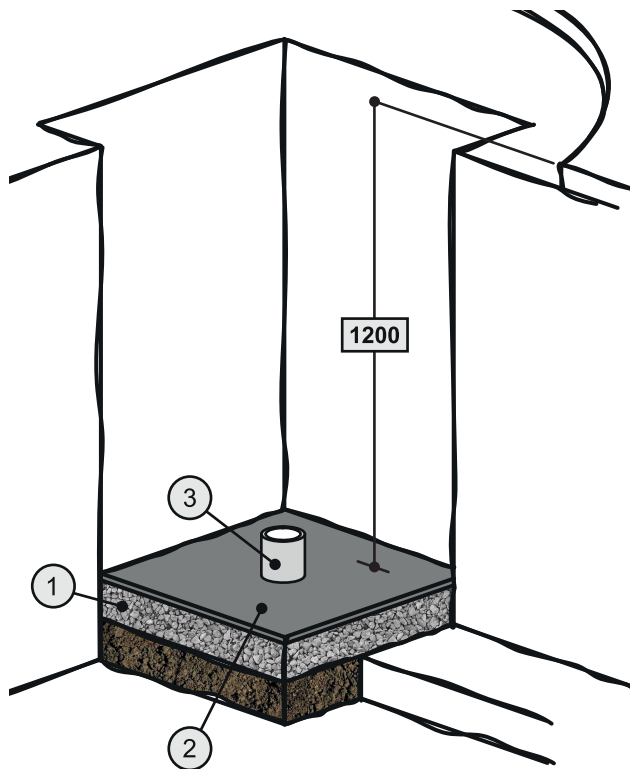

1	Ghiaia - Gravel - Gravier - Kies - Grava - Gravelha - Žwir - Гравий	2	Geotessuto - Geotextile - Géotextile - Geotextilschicht - Geotejido - Geotêxtil - Geowłókninie - Геотекстиля
3	Tubo di scarico - Drainpipe - Tuyau d'échappement - Entwässerungrohr - Tubo de escape - Rura wydechowa - Выхлопная труба	4	Raccordo a rete fognaria - Connection to sewer system - Raccord au système d'égout - Kanalisationsanschluss - Conexión al sistema de alcantarillado - Junção a sistema de águas residuais - Połączenie systemu kanalizacyjnego - Штуцер канализации

4c

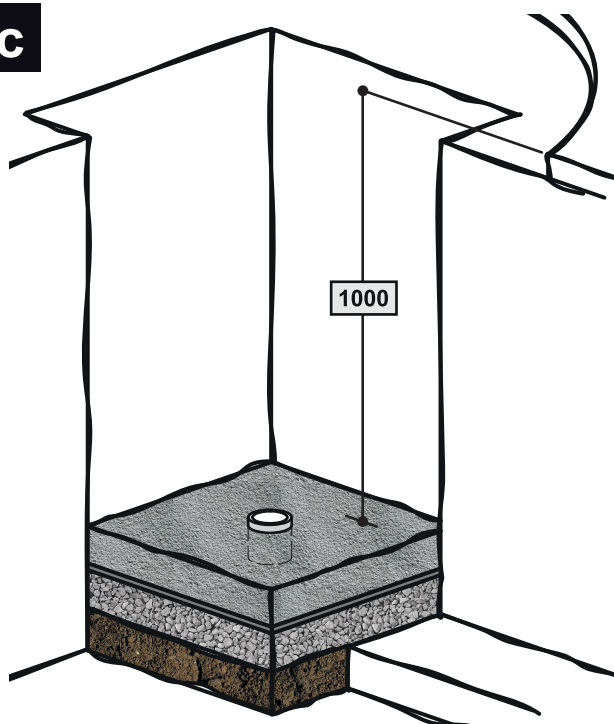

Attenzione: assicurarsi che la quota dalla base della cementazione appena eseguita al manto stradale sia di 1000 mm;

Warning: make sure that the height from the base of the cementing just performed is 1000 mm at the road surface;

Attention: s'assurer que la hauteur à partir de la base de la cimentation qui vient d'être exécutée au revêtement de la route, soit de 1000 mm;

Achtung: Die Höhe von der Basis des gerade ausgeführten Betongusses bis zur Fahrbahnoberfläche muss 1000 mm betragen;

Atención: asegúrese que la cuota de la base de la cementación apenas realizada en el pavimento sea de 1000 mm;

Atenção: assegurar-se que a quota da base da cementação apenas realizada no manto rodoviária seja de 1000 mm;

Uwaga: upewnić się, że wysokość od podstawy tyle co wykonanego cementowania na nawierzchni drogi wynosi 1000 mm;

Внимание: убедиться, что высота от основания только что выполненного цементирования до поверхности дороги, составляет 1000 мм.

5

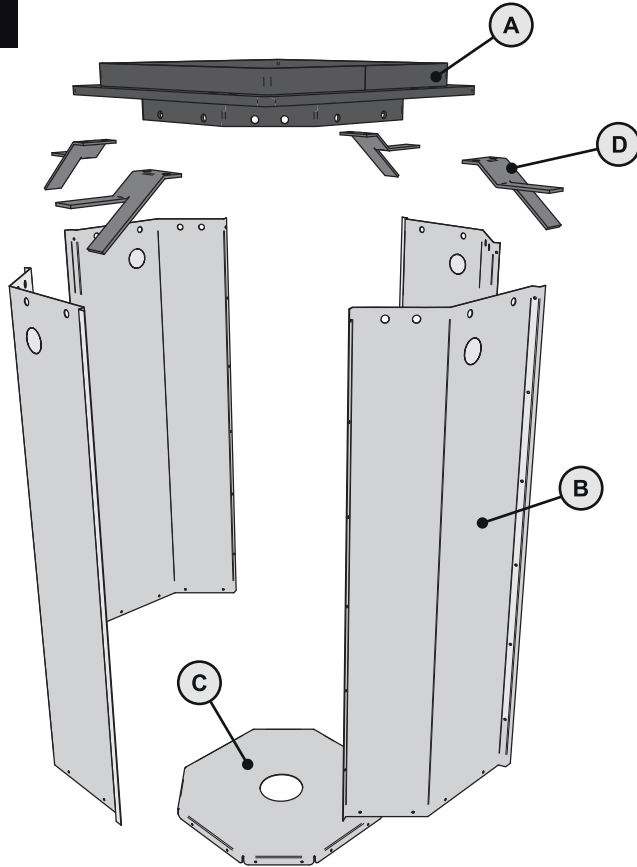

A		x1
B		x4
C		x1
D		x4
		x40
		x24

6a

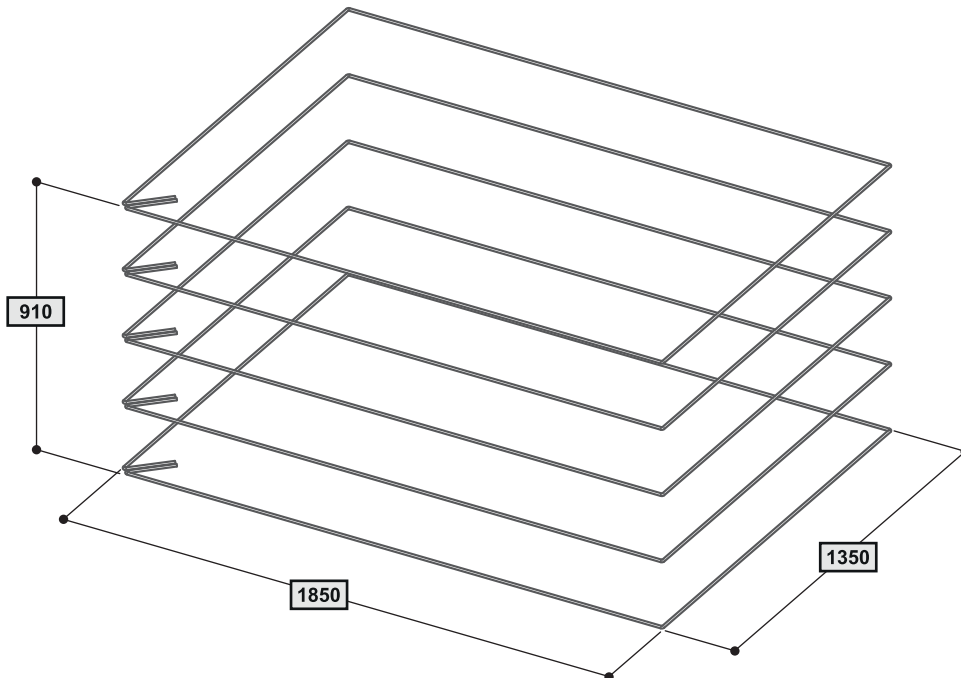

6b

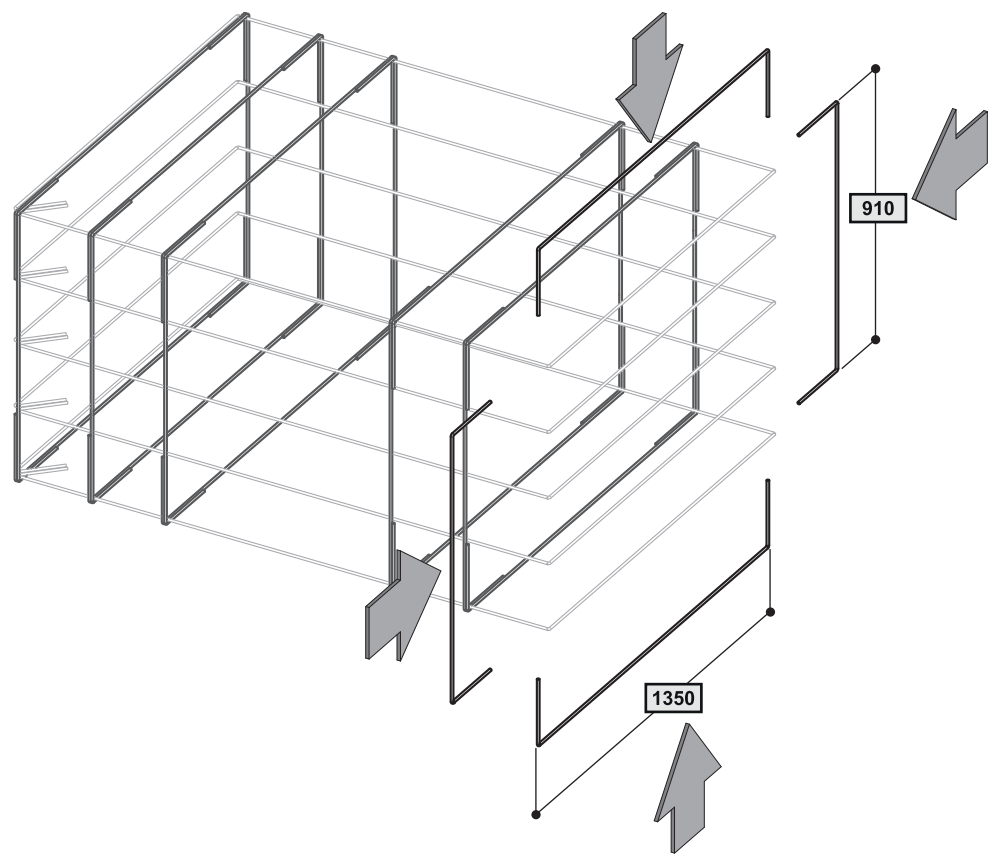

6c

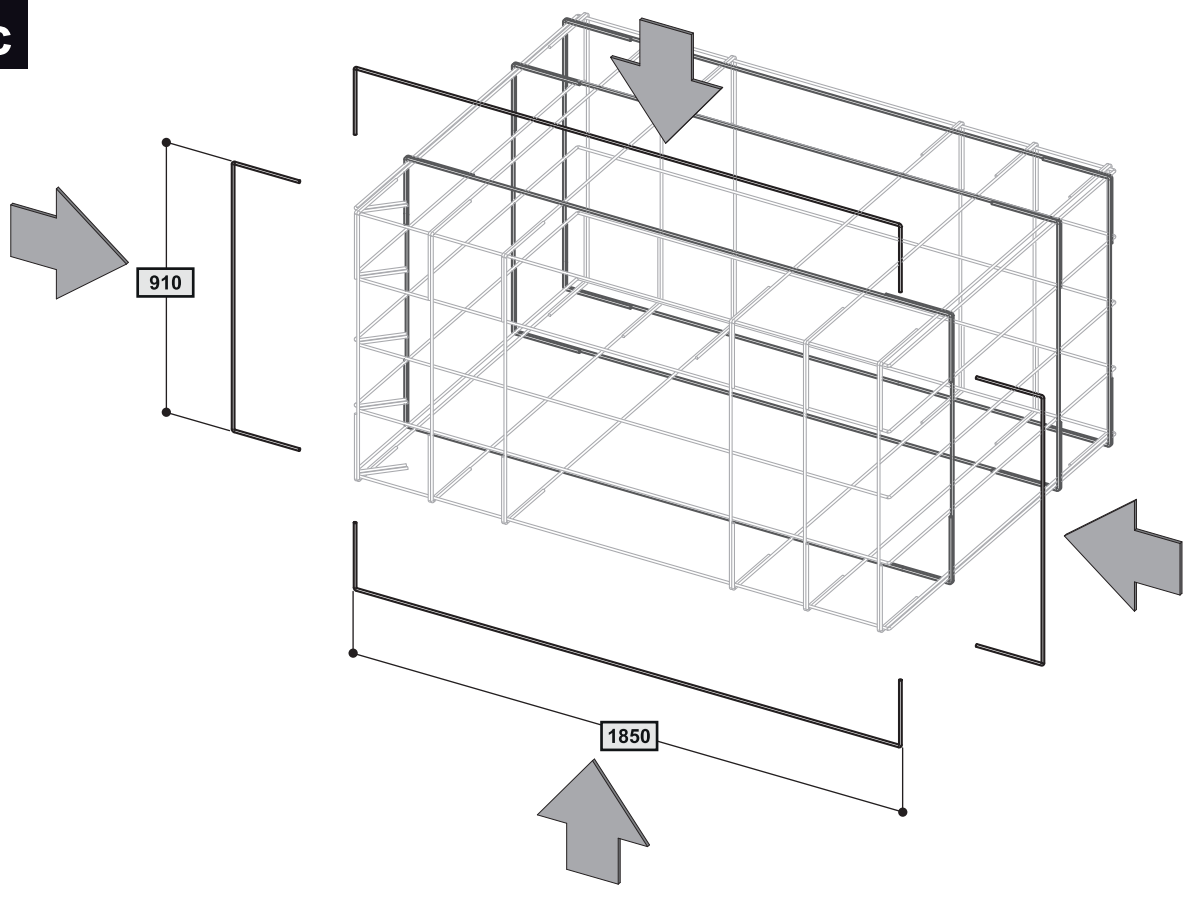

7

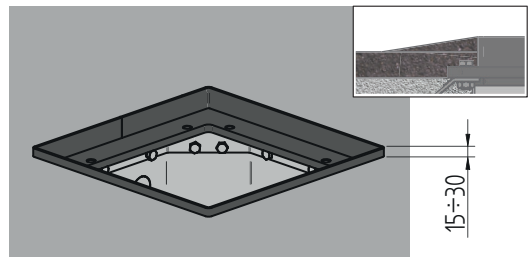
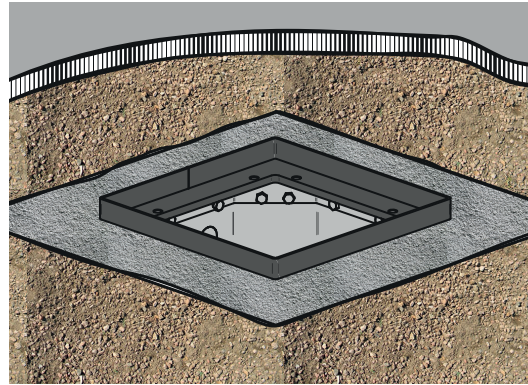
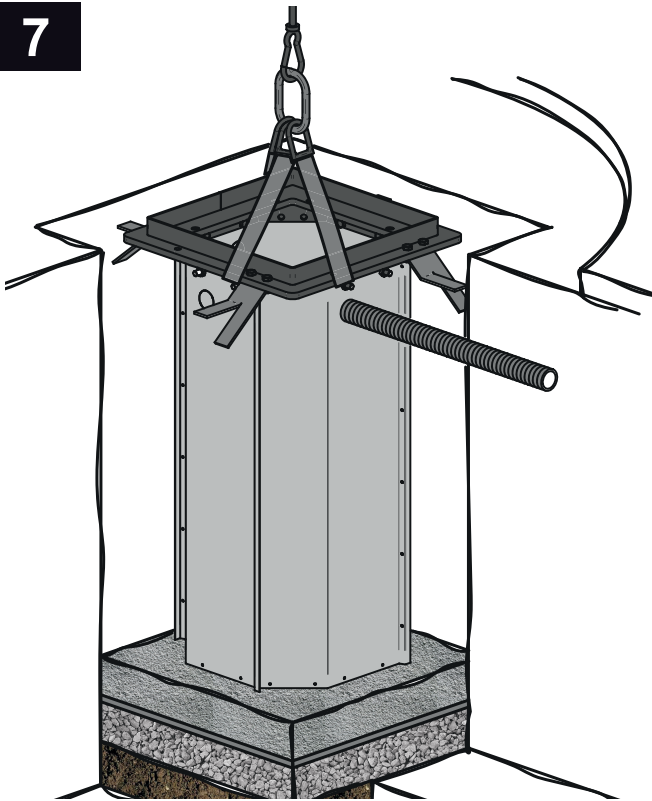

8

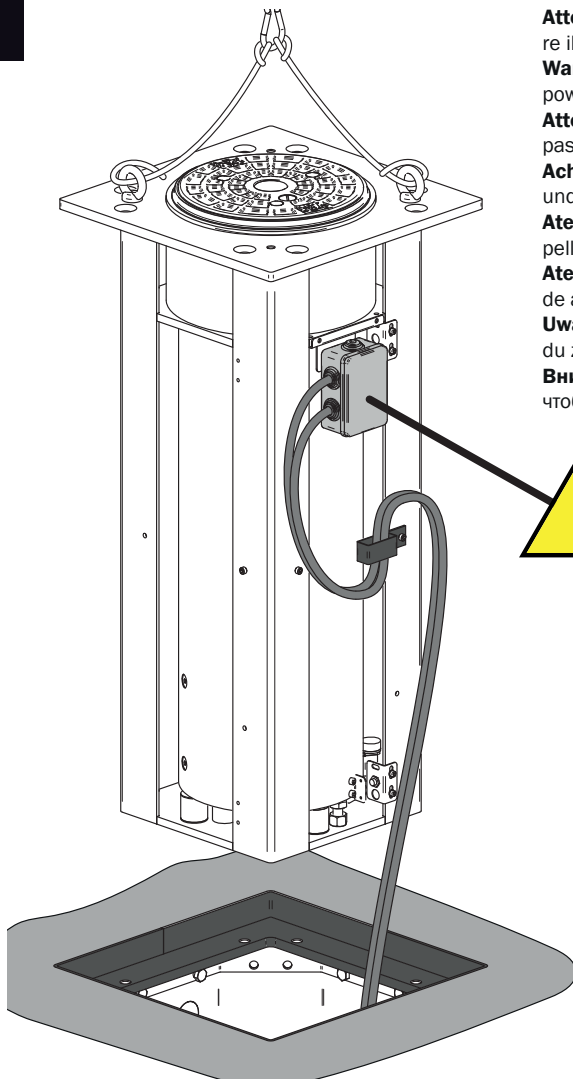

Attenzione: nel calare la struttura, prestare massima attenzione a non pizzicare il cavo di alimentazione e alla posizione della scatola elettrica;

Warning: on lowering the structure, pay maximum attention not to pinch the power supply cable and to the position of the electrical box;

Attention: au moment de faire descendre la structure, faire très attention à ne pas pincer le câble d'alimentation et à la position du boîtier électrique;

Achtung: Achten Sie beim Absenken des Pollers darauf, dass das Netzkabel und die Position des Schaltgehäuses nicht eingeklemmt oder angestoßen wird;

Atención: durante la bajada de la estructura preste la máxima atención a no pellizcar el cable de alimentación y a la posición de la caja eléctrica;

Atenção: ao abaixar a estrutura, prestar a máxima atenção a não picar o cabo de alimentação e à posição da caixa elétrica;

Uwaga: podczas opuszczania kolumny należy uważać, aby nie przeciąć przewodu zasilającego i nie naruszyć pozycji puszkii elektrycznej;

Внимание: при опускании конструкции обратить особое внимание на то, чтобы не пережать шнур питания и положение электрического блока.

9

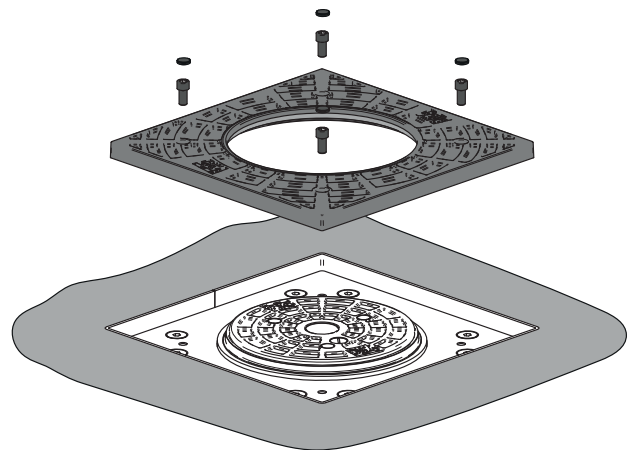
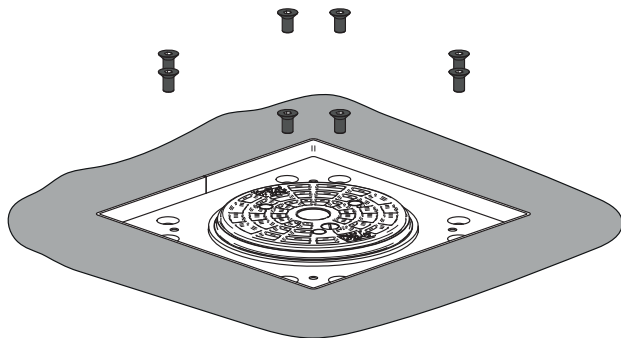

10



Tabella "ACCESSORI PRODOTTO", Table "PRODUCT ACCESSORIES", Tableau "ACCESSOIRES PRODUITS", Tabelle „PRODUKTZUBEHÖR“, Tabla "ACCESORIOS PRODUCTO", Tabela "ACESSÓRIOS DO PRODUTO", Tabela "AKCESORIA DODATKOWE", Таблица "АКСЕССУАРЫ ИЗДЕЛИЯ".

Article Code	Descrizione, Description, Description, Beschreibung, Descripción, Descrição, Opis, Описания	
ROCK/LOCK 659022		<p>Serratura di sicurezza per dissuasore art. ROCK - Safety lock for bollard art. ROCK - Serrure avec clé personnalisée pour déverrouillage art. ROCK - Sicherheitsschloss zu Poller Art. ROCK - Cerradura de seguridad para disuasor art. ROCK - Fechadura de segurança para dissuasor de estacionamento art. ROCK - Skrzynia montażowa dla art. ROCK - Предохранитель для арт. ROCK</p>
ROCK/B 659070		<p>Cassaforma per dissuasore art. ROCK Ø=273mm h=700mm - Framework for bollard art. ROCK Ø=273 h=700mm - Caisson de fondation pour borne escamotable art. ROCK Ø=273 h=700mm - Einlassrahmen zu Poller Art. ROCK Ø=273 h=700mm - Cajón de cimentación art. ROCK Ø=273 h=700mm - Estrutura para dissuasor art. ROCK Ø=273 h=700mm - Skrzynia fundamentowa dla art. ROCK Ø=273mm h=700mm - Опалубка для изделия для столбиков ROCK Ø = 273 мм h = 700 мм</p>
ROCK/RE 659060		<p>Riscaldatore elettrico antigelo - Antifreeze heater - Dispositif de chauffage électrique antigel - Frostschutzheizung - Calentador eléctrico - Aquecedor eléctrico anti-gelo - Podgrzewacz elektryczny zapobiegający zamarzaniu - Антифриз Электрический подогреватель</p>
ROCK/EL 659062		<p>Solenoid per valvola discesa rapida - Solenoid with power supply cable - Electrovanne avec câble d'alimentation - Magnet mit Netzkabel - Electroválvula con cable de alimentación - Electrovalvula com cabo de alimentação - Elektrozawór z kablem zasilającym - Электромагнитный клапан для быстрого спуска</p>
ROCK/C 659071		<p>Chiusino per cassaforma per dissuasore art. ROCK - Manhole close for bollard art. ROCK - Couvercle du caisson de fondation pour borne escamotable art. ROCK - Schachtdeckel zu Poller Art. ROCK - Tapa para cajón de cimentación art. ROCK - Tampa para a estrutura do dissuasor de estacionamento art. ROCK - Studzienka podziemna dla art. ROCK - Крышка люка для арт. ROCK</p>
ROCK/MICRO 659063		<p>Microinterruttore di sicurezza opzionale - Optional safety microswitch - Microinterrupteur de sécurité en option - Optionaler Sicherheitsmikroschalter - Microinterruptor de seguridad opcional - Microinterruptor de segurança opcional - Opcjonalny mikroprzełącznik bezpieczeństwa - По желанию микровыключатель безопасности</p>

INSTRUCTIONS FOR THE FINAL USER

This guide has been prepared for the final users of the automatism; the installer is required to deliver this guide and illustrate its contents to the person in charge of the system. The latter must then provide similar instruction to all the other users. These instructions must be carefully conserved and easily available for consultation when required.

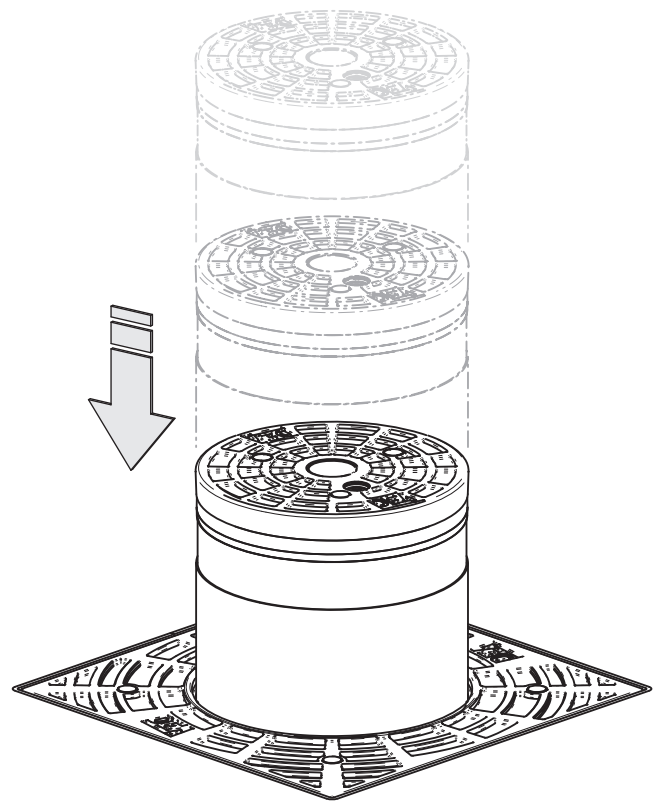
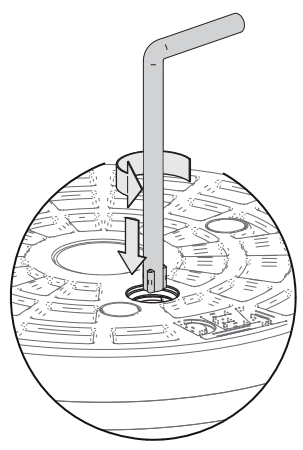
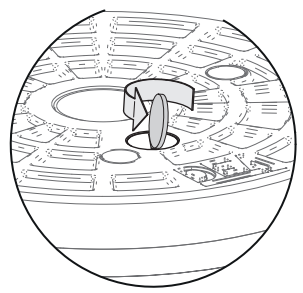
Good preventive maintenance and frequent inspection ensures the long working life of the product. Contact the installer regularly for routine maintenance and in event of anomaly.

SAFETY RULES

1. Always keep a safe distance from the automatism during operation and never touch any moving part.
2. Prevent children from playing near the automatism.
3. Perform the control and inspection operations prescribed in the maintenance schedule and immediately stop using the automatism whenever signs of malfunction are noted.
4. Never disassemble parts of the product! All maintenance and repair operations must be performed only by qualified personnel.
5. The release operation must sometimes be performed in emergencies! All users must be instructed on the use of the release mechanism and the location of the release keys.

ROCK RELEASE MECHANISM

All ROCK models have an unlocking system; the working of this system is the following. Unscrew the closure cap positioned on the head of the bollard; Insert the relevant key supplied, loosen anti-clockwise by approx. 1 turn and wait for the bollard to descend completely.

To take the bollard back to working condition, turn the key clockwise.

WARNING: The bollard may have uncontrolled movements during the release operation: pay maximum attention in order to prevent every possible risk.

WARNING: Remember to tighten the cap on completion of the manual handling operations, so that the release device is always protected from water and dust.

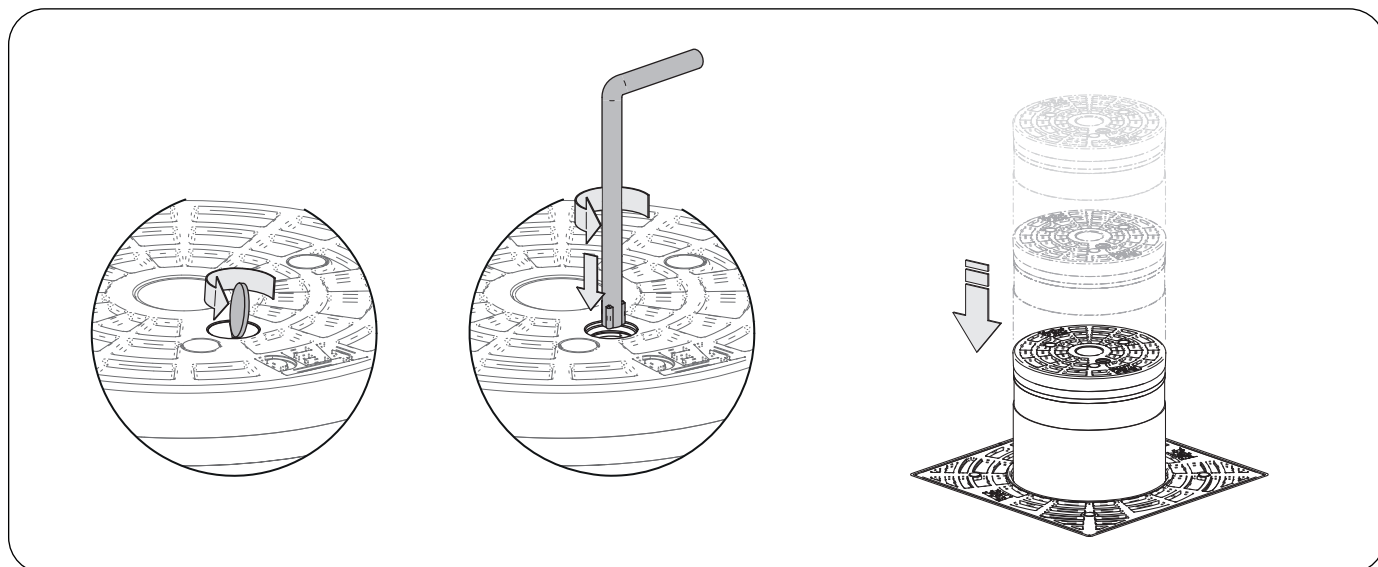

CLEANING AND INSPECTIONS

The only operation that the user can and must do is to remove leaves, branches and any other debris that restricts the movement from ROCK. **Warning! Always disconnect the power supply whenever performing operations on the gate!**



EU Declaration of Conformity (DoC)

pursuant to the Machinery Directive 2006/42/CE, Att.II, A

Company name:	DEA SYSTEM S.p.A.
Postal address:	Via Della Tecnica, 6
Postcode and City:	36013 Piovene Rocchette (VI) - ITALY
Telephone number:	+39 0445 550789
E-Mail address:	deasystem@deasystem.com

declare that the DoC is issued under our sole responsibility and belongs to the following product:

Apparatus model/Product:	ROCK – ROCK/CABLE
Type:	Hydraulic traffic bollard
Batch:	See the label on the back of the user manual

The object of the declaration described above is in conformity with the relevant Union harmonisation legislation:

Directive 2006/42/CE (MD Directive)
 Directive 2014/53/EU (RED Directive)
 Directive 2011/65/EU (RoHS)

The following harmonised standards and technical specifications have been applied:

Title:	Date of standard/specification
EN61000-6-2	2005 + EC:2005
EN61000-6-3	2007 + A1:2011
EN301 489-1 v2.1.1	2017
EN301 489-3 v2.1.1	2017 final draft
EN60204	2006
EN300 220-2 v3.1.1	2017
EN124-1	2015
EN124-3	2015
EN50581	2012

Additional information

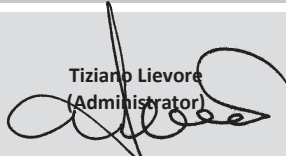
Signed for and on behalf of:		
Revision:	Place and date of issue:	Name, function, signature
00.01	Piovene Rocchette (VI) 11/01/19	Tiziano Lievore (Administrator) 



BATCH



DEA SYSTEM S.p.A.

Via Della Tecnica, 6 - 36013 PIOVENE ROCCHETTE (VI) - ITALY

tel: +39 0445 550789 - **fax:** +39 0445 550265

Internet: <http://www.deasystem.com> - **E-mail:** deasystem@deasystem.com