

# SPACE

- SPACE
- SPACE L
- SPACE XL
- SPACE XXL

**DEA**<sup>®</sup>

move as you like



- IT** Operatore elettromeccanico per porte sezionali  
*Istruzioni d'uso ed avvertenze*
- EN** Sectional door electromechanical operator  
*Operating instructions and warnings*
- FR** Moto-reducteur pour portes sectionnelles  
*Notice d'emploi et avertissements*
- DE** Elektromechanischer Antrieb für Schwing- und Sektionaltore  
*Bedienungsanleitung und Hinweise*
- ES** Operador electromecánico para puertas seccionales  
*Instrucciones de uso y advertencias*
- PT** Operador electromecânico para portas seccionais  
*Instruções para utilização e advertências*
- PL** Urządzenie elektromechaniczne do bram segmentowych  
*Instrukcja montażu i użytkowania*
- RU** Электро-механический привод для секционных ворот  
*Инструкции и предупреждения*

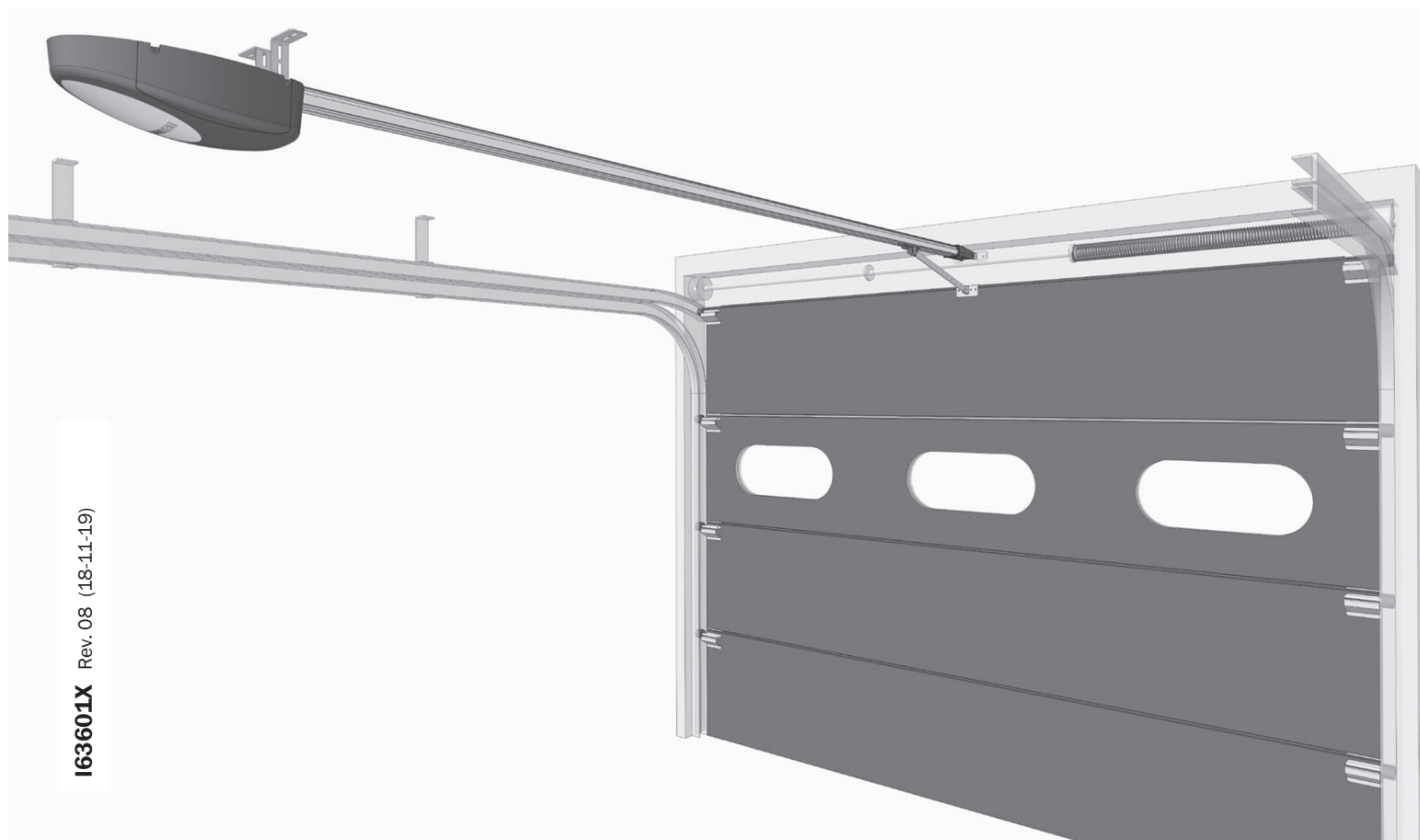



# SPACE

## Sectional door electromechanical operator



Operating instructions and warnings

### Index

<b>1</b>	Warnings Summary	<b>25</b>	<b>6</b>	Standard Programming	<b>34</b>
<b>2</b>	Product Description	<b>27</b>	<b>7</b>	Advanced Programming	<b>36</b>
<b>3</b>	Technical data	<b>28</b>	<b>8</b>	Messages shown on the Display	<b>41</b>
<b>4</b>	Installation and Assembly	<b>28</b>	<b>9</b>	Start-up	<b>42</b>
<b>5</b>	Electrical Connections		<b>10</b>	Maintenance	<b>42</b>
<b>5.1</b>	- SPACE	<b>30</b>	<b>11</b>	Product Disposal	<b>43</b>
<b>5.2</b>	- SPACE L / SPACE XL / SPACE XXL	<b>32</b>			

### SYMBOLS

The following symbols are used within this manual to indicate potential hazards.

	Important safety notice. Any failure to observe this notice could result in personal injuries or even death. Injuries. Any failure to observe these instructions could result in serious damage or even the complete destruction of the product.
	Important safety notice. Contact with the electrical power components could result in personal injuries or even death.
	Important notice for professional installation, programming and commissioning.

## 1 WARNINGS SUMMARY

**WARNING! IMPORTANT SAFETY INSTRUCTIONS. CAREFULLY READ AND FOLLOW ALL WARNINGS AND INSTRUCTIONS THAT ACCOMPANY THE PRODUCT SINCE INCORRECT INSTALLATION COULD CAUSE HARM TO PEOPLE, ANIMALS OR THINGS. WARNINGS AND INSTRUCTIONS PROVIDE IMPORTANT INFORMATION REGARDING SAFETY, INSTALLATION, USE AND MAINTENANCE. KEEP THE INSTRUCTIONS TOGETHER THE TECHNICAL DOCUMENTATION AND FOR FUTURE REFERENCE.**

 **WARNING** The device may be used by children of less than 8 years of age, people with reduced physical, mental or sensory impairment, or generally anyone without experience or, in any case, the required experience provided the device is used under surveillance or that users have received proper training on safe use of the device and are aware of the dangers related to its use.

 **WARNING** Fixed installation command (buttons, etc.) must be situated out of the reach of children at a height of at least 150 cm from the ground. Do not allow children to play with the device, the fixed commands or the radio controls of the system.

 **WARNING** Product use in abnormal conditions not foreseen by the manufacturer may generate hazardous situations; meet the conditions indicated in these instructions.

### INTENDED USE:

The drive unit is designed for the automation of non-commercial garage doors and balanced garage doors with integrated fall protection, within the specified technical limits.

 **WARNING DEA** System reminds all users that the selection, positioning and installation of all materials and devices which make up the complete automation system, must comply with the European Directives 2006/42/CE (Machinery Directive), 2014/53/UE (RED Directive). In order to ensure a suitable level of safety, besides complying with local regulations, it is advisable to comply also with the above mentioned Directives in all extra European countries.

 **WARNING** Under no circumstances use the device in an explosive atmosphere or in areas that may be corrosive or could damage product parts. Check that the temperatures at the installation site are suitable and comply with the temperatures declared on the product label.

 **WARNING** When working with the “dead man” switch, make sure that there are no people in the area where the automatism is being used.

 **WARNING** Check that there is a switch or an omni polar magneto-thermal circuit breaker that enables complete disconnection in case of over voltage category III conditions installed upstream from the power system.



 **WARNING** To ensure an appropriate level of electrical safety always keep the 230V power supply cables apart (minimum 4mm in the open or 1 mm through insulation) from low voltage cables (motors power supply, controls, electric locks, aerial and auxiliary circuits power supply), and fasten the latter with appropriate clamps near the terminal boards.

 **WARNING** If the power cable is damaged, it must be replaced by the manufacturer or its technical assistance service or, in any case, by a person with similar qualifications to prevent any risk.

 **WARNING** All installation, maintenance, cleaning or repair operations on any part of the system must be performed exclusively by qualified personnel with the power supply disconnected working in strict compliance with the electrical standards and regulations in force in the nation of installation.

Cleaning and maintenance destined to be performed by the user must not be performed by unsupervised children.

 **WARNING** Using spare parts not indicated by **DEA** System and/or incorrect re-assembly can create risk to people, animals and property and also damage the product. For this reason, always use only the parts indicated by **DEA** System and scrupulously follow all assembly instructions.

  **FORCE ADJUSTMENT WARNING:** Changing the closure force could result in hazardous situations. The closure force must therefore only be increased by qualified personnel. After adjustment, compliance with regulatory limits values should be detected with a force impact measuring instrument. The sensitivity of the obstacle detection may be adjusted gradually to the door (see programming instructions). The anti-crushing device operation must be checked after each manual adjustment. Manual modification of the force can only be done by qualified personnel by performing the measurement test according to EN 12445. Modifications to the force adjustment must be documented in the machine manual.

 **WARNING** The compliance of the internal sensing obstacles device to requirements of EN12453 is guaranteed only if used in conjunction with motors fitted with encoders.

 **WARNING** Any external security devices used for compliance with the limits of impact forces must be conform to standard EN12978.

**WARNING** In compliance with EU Directive 2012/19/EG on waste electrical and electronic equipment (WEEE), this electrical product should not be treated as municipal mixed waste. Please dispose of the product and bring it to the collection for an appropriate local municipal recycling.

**EVERYTHING THAT IS NOT EXPRESSLY PROVIDED FOR IN THE INSTALLATION MANUAL IS NOT ALLOWED. CORRECT OPERATOR OPERATION IS ONLY ENSUED WHEN THE REPORTED DATA IS RESPECTED. THE COMPANY DOES NOT RESPOND FOR DAMAGE CAUSED BY FAILURE TO COMPLY WITH THE INSTRUCTIONS CONTAINED IN THIS MANUAL. WITHOUT AFFECTING THE ESSENTIAL FEATURES OF THE PRODUCT, THE COMPANY RESERVES THE RIGHT TO MAKE ANY CHANGES DEEMED APPROPRIATE AND AT ANY TIME IN ORDER TO TECHNICALLY, STRUCTURALLY AND COMMERCIALY IMPROVE THE PRODUCT WITHOUT BEING REQUIRED TO UPDATE THIS DOCUMENT.**

## 2 PRODUCT DESCRIPTION

### 2.1 Models and contents of the package

The SPACE product range consists of a family of 24V electromechanical operators for balanced spring-operated doors and sectional doors. All the motorized models require the use of control units (NET series). The SPACE drive unit is designed for the automation of non-commercial garage doors and balanced garage doors with integrated fall protection, within the specified technical limits.

**The drive unit can be used on the following types of doors:**



**Sectional doors**

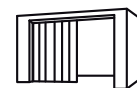

**Side tilting doors**

Check the "Packaging content" (Fig. 1) and compare them with your product; this could be useful during assembly.

### 2.2 Transport and storage

The SPACE models are always delivered in boxes that provide the product with adequate protection; always respect the storage and handling indications shown on the boxes themselves. Depending on the version and the track type, the furnished product may differ from the illustrations contained within this manual. The drive unit must be stored/transported lying down at a temperature of  $-20^{\circ}\text{C}$  to  $+40^{\circ}\text{C}$ , with a relative humidity value of RF 20 - 80%, without condensation. The maximum height of the stacks are as follows: 6 motor heads, 6 tracks or else 6 complete Kits packed in cardboard boxes. The stacked units must be secured in order to prevent tipping.

### 3 TECHNICAL DATA

OPERATOR				
	SPACE	SPACE L	SPACE XL	SPACE XXL
Motor power supply voltage (V)	24 V ===			
Absorbed power (W)	100	120	180	230
Max Thrust (N)	600	800	1200	1200
Work cycle (cycles/hour)	20	25	25	35
Maximum n° of operations in 24	60	75	75	350
Operating temperature range (°C)	-20÷50 °C			
Opening speed (cm/s)	17	17	16	13
Weight of product with package (Kg)	5			6
Sound pressure emitted (dBA)	< 70			
Protection degree	IP 20			
CONTROL BOARD				
	NET724N	NET724N XL		
Power supply (V)	220 - 240 V ~ ±10% (50/60 Hz)			
Rated power transformer (VA)	80 VA (230/25V)	150 VA (230/25V)		
Fuse F1 (A)	T2A 250V (retarded)			
Auxiliaries power supply output	-	24 V ===		
Stabilized power supply output for safety devices	24 V === max 200mA	(24V_AUX + 24V_ST = max 200mA)		
Configurable Output 1	24 V === max 5 W			
Configurable Output 2	24 V === max 5 W			
Receiver frequency	433,92 MHz			
Transmitters type of coding	HCS fix-code - HCS rolling code - Dip-switch - DART			
Max remote controllers managed	100			

### 4 INSTALLATION AND ASSEMBLY

#### 4.1 For a satisfactory installation of the product is important to:



- **The drive unit can only be mounted on garage doors that are in perfect mechanical condition:**

The door must be thoroughly inspected (with particular regard to the springs, wheels/wheel supports, ropes, and hinges) in order to check for any wear and/or damage. Furthermore, check to make sure that all the fastening screws have been tightened in a secure and stable manner.

- **Check the door's balance and smoothness of movement:**

The door must be easy to manoeuvre manually along its entire stroke;

The door must maintain its position without moving when stopped in its open or closed positions, or at any intermediate position.

**If any damage is encountered prior to installing the drive unit (wear or difficulties moving the door), stop using the door immediately and have it repaired by qualified personnel!**

- Check to make sure that the encumbrance of the drive unit/ track (Fig. 7a - d) is compatible with the selected installation zone.
- The device requires a 230V power outlet. This must be installed at about 50 cm from the control unit by a qualified electrician.

#### 4.2 Preparation for assembly (Fig. 7)

- Measure the width of the door, and mark the centre line on the top edge of the door and on the lintel.
- Recommendation for the track's proper assembly on the door's longitudinal axis. Open the garage door completely and mark the sign previously made on the top edge of the door on the ceiling as well.
- Open and close the door completely, and take note of the highest point reached by the door (TLP). The "TLP" is the point with the smallest distance between the edge of the door and the ceiling.
- The distance between the TLP and the track/motor head should be 10-20 mm. It is recommended to maintain an angle equal to or less than 30° between the towing arm and the track on the ceiling.
- Make sure that the track is perfectly horizontal with respect to the ceiling once assembled.
- If the installation is to be carried out under conditions different from those indicated, it may be necessary to use additional angular and/or slotted mounting brackets. Any additional brackets must be cut, deburred, and mounted as shown in Fig. 7.
- For safety reasons, the suspension brackets must always be cut well below the holes to be used for fastening (Fig. 7d).

## 4.3 Assembly

### ASSEMBLING THE TRACK (Fig. 3)

Join the two halves of the track using the coupling (verify the proper insertion side), and push until the stopper in the track is reached.

### ADJUSTING THE BELT-TENSIONER (Fig. 4)

The belt's tension must be adjusted using the tensioner on the end of the track. In order to avoid damaging the automation's mechanical components, the belt must not be overtightened.

### MOUNTING THE TRACK ON THE CEILING (Fig. 7)

Mount the belt track in the centre with respect to your door.

**Note:** The centre of the garage and the centre of the door may be different.

Use tools and fastening materials that are suitable for the installation site's conditions.

### ASSEMBLING THE MOTOR HEAD ON THE CEILING TRACK (Fig. 6)

Align the motor head: Align the motor head's front attachment with the support on the track, and insert it; Secure the motor head against the risk of falling. If it cannot be inserted perfectly: turn the belt/chain drive pulley slightly and try again. Screw in the motor head using the supplied screws and toothed washers.

## 4.4 How to release the gear motor (Fig. 5)

In the event of a malfunction or power failure, the motor can be released as shown in Fig. 5a or 5b in order to move the door manually.

**CAUTION** The safety and efficacy of moving the automation manually is only guaranteed by **DEA** System if the system has been properly installed using original accessories.

## 5.1 ELECTRICAL CONNECTIONS FOR THE SPACE MODEL



**! Risk of malfunction due to improper installation !**



**! Risk of personal injury and property damage due to electric shocks !**

Execute the wiring following the directions of “Table 1” and diagram (Pag. 31).

**WARNING** To ensure an appropriate level of electrical safety always keep the 230V power supply cables apart (minimum 4mm in the open or 1 mm through insulation) from low voltage cables (motors power supply, controls, electric locks, aerial and auxiliary circuits power supply), and fasten the latter with appropriate clamps near the terminal boards.

**WARNING** Connect to the power supply 230 V  $\sim \pm 10\%$  50 Hz through a multi pole switch or a different device that can ensure multi pole disconnection from the power supply, with a contact opening of 3 mm.

**Table 1 “terminal board connections”**

<b>1-2-3-4</b>		Motor 1 encoder output	
<b>5-6</b>		Motor 1 output max 5A	
<b>7-8</b>	7 (+)	Configurable 24V $\equiv$ output 1 max 5W (see P066 for values that can be selected)	If the installation requires different commands and / or additional to the standard, you can configure each input to the required rate. <b>Refer to Chapter “Advanced Programming”.</b>
	8 (-)		
<b>9-13</b>	9 - N.O.	Input 4. Unused	
	13 - Com		
<b>10-13</b>	10 - N.O.	Input 3. Unused	
	13 - Com		
<b>11-13</b>		Input 2 START. In case of intervention it provokes: the operator opening or closing. It may operate as “inversion” mode (P049=0) or “step by step” mode (P049=1).	
	13 - Com		
<b>12-13</b>		Input 1 PHOTO 1. When enabled (see parameter P050 in the table), activation of PHOTO 1 provokes: an inversion of direction (during closing), the arrest of the movement (during opening), prevent the start (gate closed). <b>If unused, short circuit.</b>	
	13 - Com		
<b>14-15</b>	+24V_ST	Stabilized 24 V $\equiv$ power supply output for tested safety devices <b>max 200mA</b>	
	15 (+)		
<b>16-17</b>	16 (+)	Configurable 24V $\equiv$ output 2 max 5W (see P062 for values that can be selected)	
	17 (-)		
<b>18</b>		Aerial signal input	
<b>19</b>		Ground aerial input	
<b>CON 1</b>		Connection of motors metallic parts	
<b>CON 2</b>	25 V ~	25 V ~ transformer power supply input	
<b>CON 3</b>		Courtesy light output	
<b>CON 4</b>		Input for NET-NODE / MEMONET connector	
<b>CON 5</b>		Input for NET-EXP connector	
<b>J4 (jumper)</b>		Operating mode selection jumper: (closed) = Normal functioning; (open) = Programming mode;	

# SPACE WIRING DIAGRAM

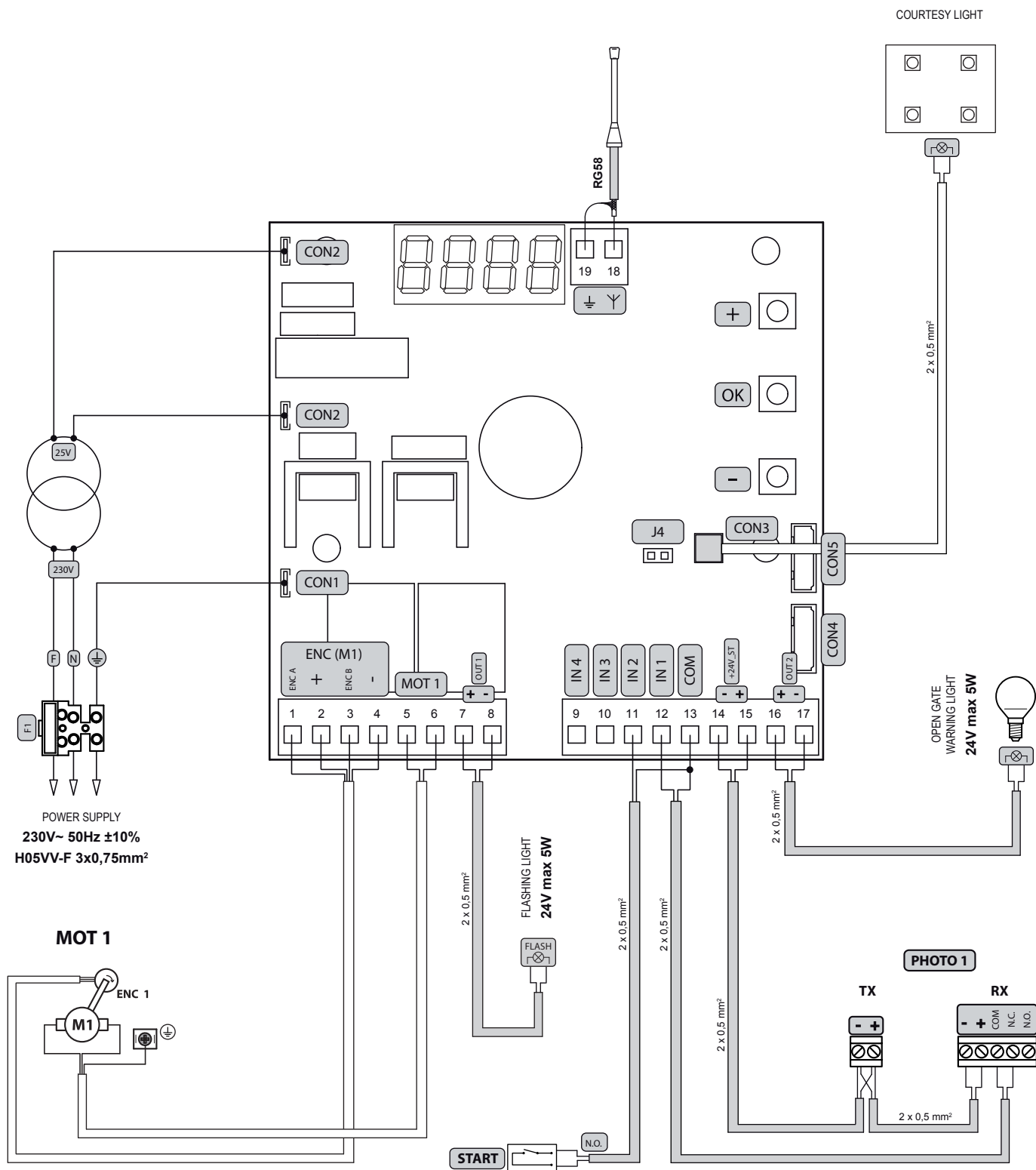
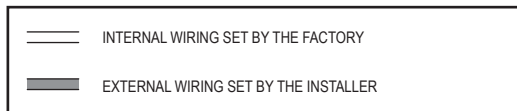

EN

## 5.2 ELECTRICAL CONNECTIONS FOR THE SPACE L/SPACE XL/SPACE XXL MODEL



**! Risk of malfunction due to improper installation !**



**! Risk of personal injury and property damage due to electric shocks !**

Execute the wiring following the directions of “Table 2” and diagram (Pag. 33).

**WARNING** To ensure an appropriate level of electrical safety always keep the 230V power supply cables apart (minimum 4mm in the open or 1 mm through insulation) from low voltage cables (motors power supply, controls, electric locks, aerial and auxiliary circuits power supply), and fasten the latter with appropriate clamps near the terminal boards.

**WARNING** Connect to the power supply 230 V  $\sim \pm 10\%$  50 Hz through a multi pole switch or a different device that can ensure multi pole disconnection from the power supply, with a contact opening of 3 mm.

**Table 2 “terminal board connections”**

<b>1-2-3-4</b>		Motor 1 encoder output	
<b>5-6</b>		Motor 1 output max 5A	
<b>7-8</b>	7 (+)	Configurable 24V $\text{---}$ output 1 max 5W (see P066 for values that can be selected)	If the installation requires different commands and / or additional to the standard, you can configure each input to the required rate. <b>Refer to Chapter “Advanced Programming”</b> .
	8 (-)		
<b>9-13</b>	9 - N.O.	Input 4. Unused	
	13 - Com		
<b>10-13</b>	10 - N.O.	Input 3. Unused	
	13 - Com		
<b>11-13</b>		Input 2 START. In case of intervention it provokes: the operator opening or closing. It may operate as “inversion” mode (P049=0) or “step by step” mode (P049=1).	
	13 - Com		
<b>12-13</b>		Input 1 PHOTO 1. When enabled (see parameter P050 in the table), activation of PHOTO 1 provokes: an inversion of direction (during closing), the arrest of the movement (during opening), prevent the start (gate closed). <b>If unused, short circuit.</b>	
	13 - Com		
<b>14-15</b>	+24V_ST	Stabilized 24 V $\text{---}$ power supply output for tested safety devices	<b>(AUX + ST)</b> <b>=</b> <b>max 200mA</b>
	14 (-)		
<b>20-21</b>	+24VAUX	24 V $\text{---}$ power supply output for auxiliary devices	
	20 (-)		
<b>16-17</b>	16 (+)	Configurable 24V $\text{---}$ output 2 max 5W (see P062 for values that can be selected)	
	17 (-)		
<b>18</b>		Aerial signal input	
<b>19</b>		Ground aerial input	
<b>CON 1</b>		Connection of motors metallic parts	
<b>CON 2</b>	25 V ~	25 V ~ transformer power supply input	
<b>CON 3</b>		Courtesy light output	
<b>CON 4</b>		Input for NET-NODE / MEMONET connector	
<b>CON 5</b>		Input for NET-EXP connector	
<b>J4 (jumper)</b>		Operating mode selection jumper: (closed) = Normal functioning; (open) = Programming mode;	

# SPACE L/SPACE XL/SPACE XXL WIRING DIAGRAM

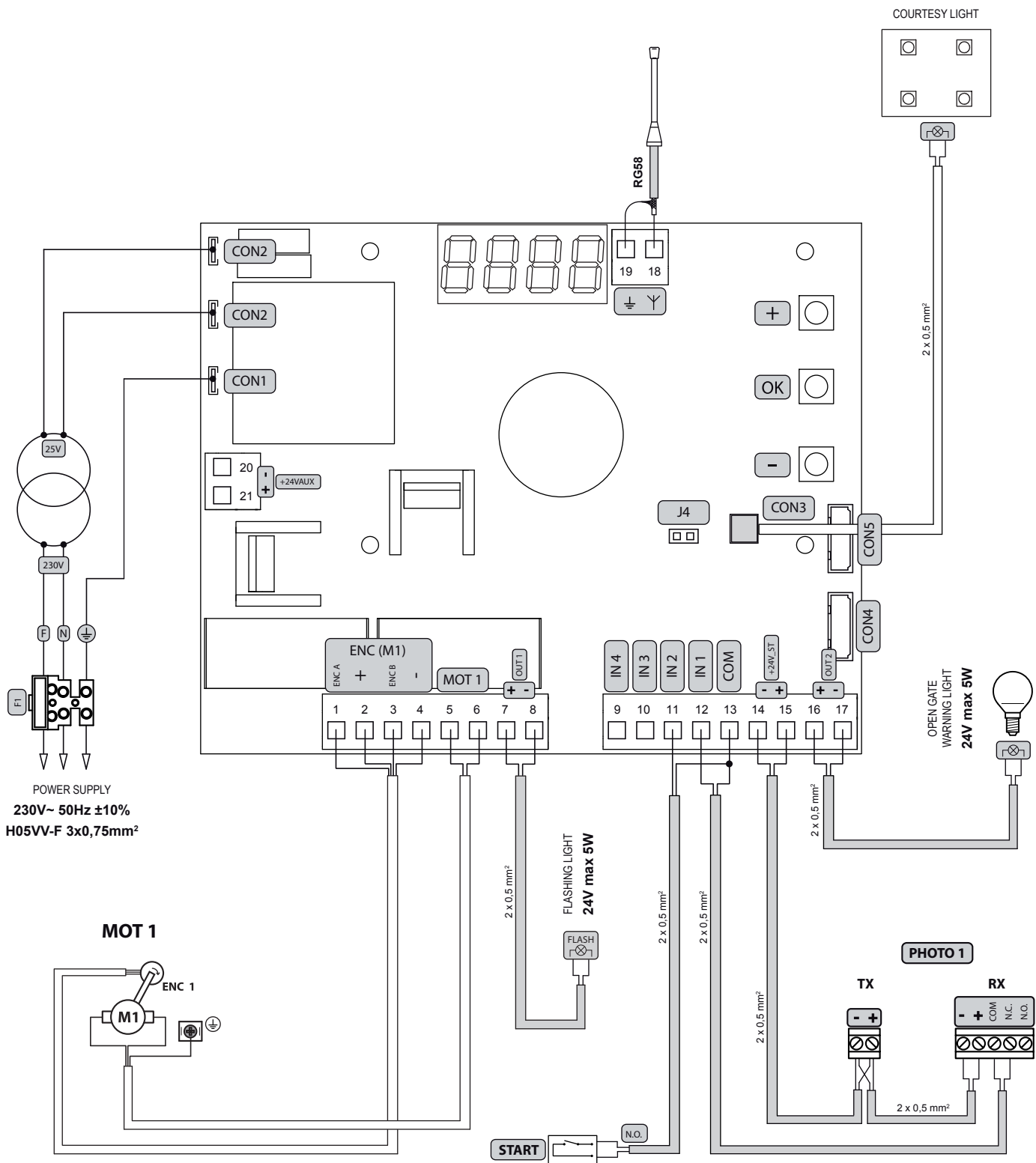
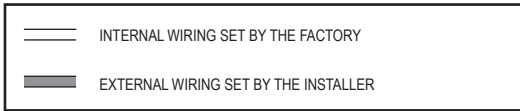

EN



### 3 Transmitters learning

1. Scroll down the parameters with **+** and **-** keys until you visualise P005;
2. Confirm by pressing on the **OK** key;
3. When the symbol "LER" appears, press on any key of the transmitter you want to memorize;
4. The display visualizes the number of the transmitter just memorized and then "LER";
5. Memorize all necessary transmitters repeating this procedure from step 3;
6. Wait 10 seconds before quitting the memorization mode, display shows now "P003".

**Warning:** In the case of rolling code remotes, the receiver can be put into learning mode by pressing the hidden button on a remote control previously learned.

**Warning:** When using personalized transmitters, after entering P005 the learning of the first personalized transmitter is possible only by pressing its hidden button. Afterwards, only transmitters personalized with the same encryption key can be memorized (through the usual procedure), unless a memory reset is carried out (P004).

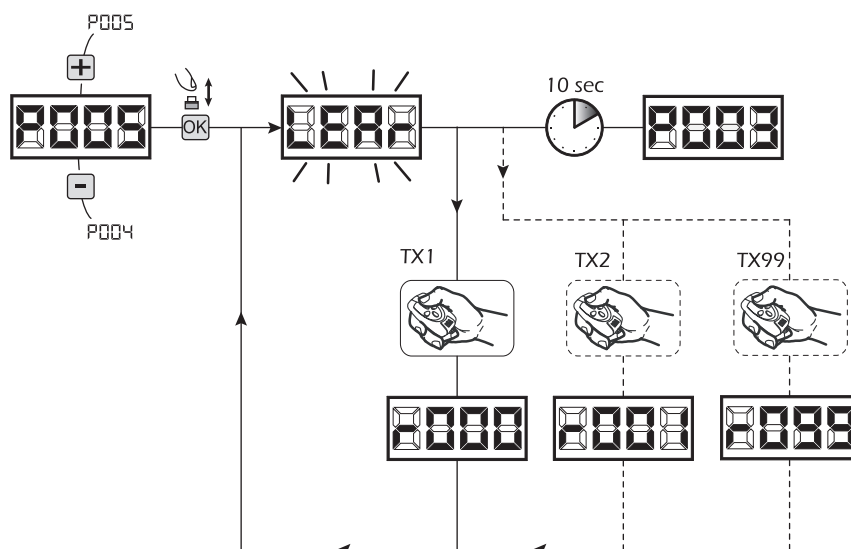

### 4 Deletion of all transmitters

1. Scroll down the parameters until you visualize P004;
2. Confirm by pressing on the **OK** key;
3. When "LER" is flashing, press the **OK** key for a few seconds;
4. Release the **OK** key as soon as "LER" stops flashing;
5. All memorized transmitters have been deleted (display shows again P004).

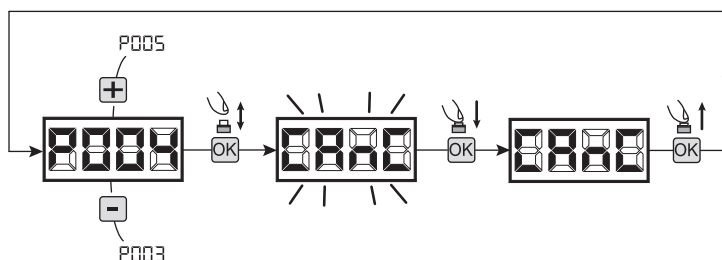

### 5 Programming complete

**WARNING** At the end of the programming procedure, **re-introduce Jumper J4, until "..." is shown on the display** and close the lid of the electric box. The automatism is now in stand-by for normal operating commands.

To perform any "Advanced Programming" operations (parameters modification, programming block/release, configuration of inputs etc.), go to page 36.

# 7 ADVANCED PROGRAMMING

Below find the description of some programming procedures relative to the management of the radio-commands memory and advanced configuration of the command inputs.

To access the control unit advanced programming functions, **remove the Jumper J4 from the board**. Use the **+** and **-** keys to go to P005 and hold the **+** key down for 5 seconds (at this point, all of the parameters are visible and can be modified).

## 1 Visualisation of inputs and operations-counter status

1. Scroll the parameters with the **+** and **-** keys until the screen reads P013;
2. Access the parameter by pressing the **OK** button;
3. The "Input Status" is shown on the screen (check that this is correct):



4. Press the **OK** button again;
5. The "Total Operation Counter"  $\Sigma$  appears on the screen followed by the multiplier.

To calculate the number of completed operations, the two values must be multiplied.

**I.e.:**  $\Sigma \times \text{multiplier} = 120 \times 10 = 1200$  operations completed

6. Press the **OK** button again;
7. The "Total Maintenance Counter"  $\Gamma$  appears on the screen followed by the multiplier.

To calculate the number of operations remaining before the maintenance request, the two values must be multiplied.

**I.e.:**  $\Gamma \times \text{multiplier} = 1500 \times 1 = 1500$  operations yet to be completed before the maintenance request

8. Press the **OK** button again to exit the parameters (P013 is shown on the screen again).

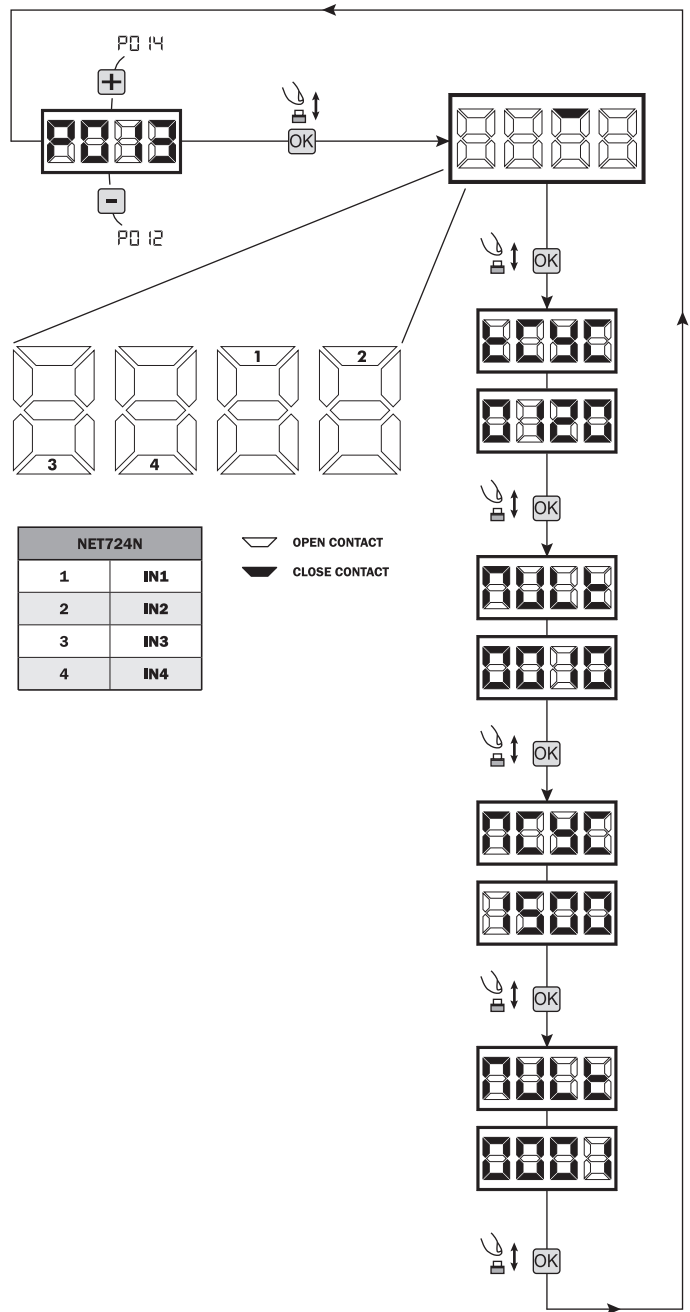

NET724N	
1	IN1
2	IN2
3	IN3
4	IN4

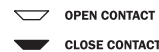

## 2 Selection type of operators

# ! IMPORTANT !

1. Scroll down the parameters with **+** and **-** keys until you visualise P028;
2. Access the parameter by pressing the **OK** key;
3. Acting on **+** and **-** keys, set:
  - d000 = SPACE
  - d001 = SPACE L
  - d002 = SPACE XL
  - d003 = SPACE XXL
4. Confirm your choice by pressing the **OK** key (display returns again to P028).

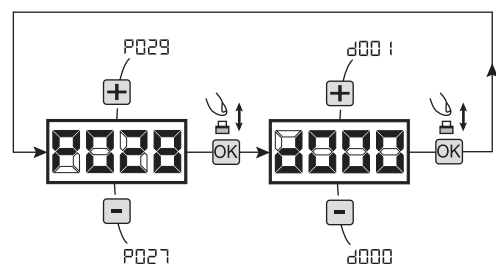

### 3 Selection operating with or without encoder

## ! IMPORTANT !

1. Scroll down the parameters with **+** and **-** keys until you visualise P029;
2. Access the parameter by pressing the **OK** key;
3. Acting on **+** and **-** keys, set:
  - d001 = 1 channel encoder;
  - d002 = 2 channel encoder;
4. Confirm your choice by pressing the **OK** key (display returns again to P029).

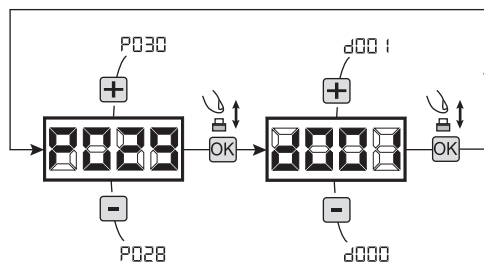

### 4 Transmitters coding selection

1. Scroll down the parameters with **+** and **-** keys until you visualise P027;
2. Confirm by pressing on the **OK** key;
3. Select the type of transmitter by scrolling **+** and **-** keys:
  - d000=fix rolling-code (**suggested**);
  - d001=complete rolling-code;
  - d002=dip-switch;
  - d003=DART;
4. Confirm by pressing on the **OK** key (display shows again P027).

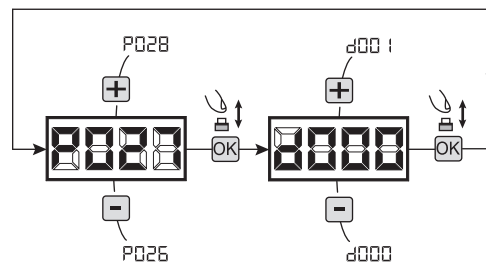

**Warning:** If you need to vary the type of encoding, and only if other remotes with different encoding are memorized, you need to erase memory (P004) **AFTER** you have set the new encoding.

### 5 Adjustment of operating parameters

If you need to modify the operating parameters (force, speedness etc.):

1. Scroll down the parameters until you visualize the desire parameter (i.g. P032);
2. Confirm by pressing on the **OK** key;
3. By pressing on **+** and **-**, set up the desired value;
4. Confirm by pressing on the **OK** key (display shows the parameters previously selected).

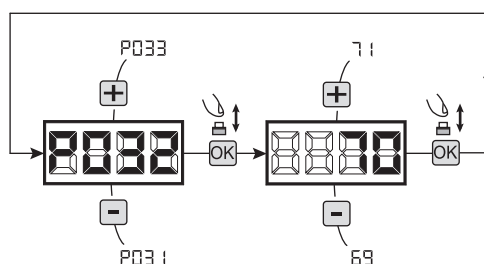

**For the complete list of the "Operating Parameters" See the table on page. 45.**

### 6 How to search and delete a transmitter

1. Scroll down the parameters until you visualize P006;
2. Confirm by pressing on the **OK** key;
3. By pressing on **+** and **-**, keys, select the transmitter you want to delete (eg. r 003);
4. When "r 003" flashes, confirm the deletion by pressing the **OK** key for a few seconds;
5. Release the **OK** key when appears "r ---";
6. The selected transmitter is deleted (display shows again P006).

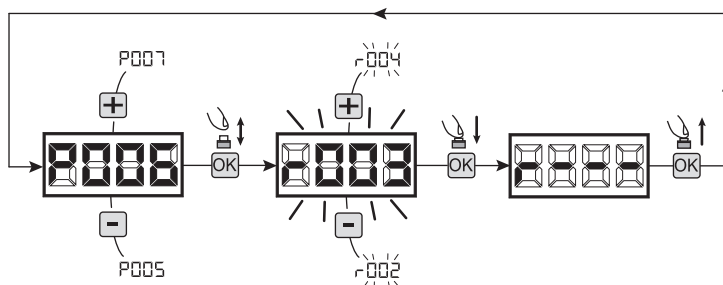

## 7 Restoring default parameters

**WARNING** At the end of the procedure, the display will be blocked on flashing “ $\square$  L - !” and motor stroke learning must be carried out again before any other operation can be carried out.

### 7.1 Restoring operating parameters

1. Scroll through the parameters with the buttons  $\oplus$  and  $\ominus$  until the display shows P007;
2. Confirm by pressing on the  $\text{OK}$  key;
3. When “dEF !” is flashing, press the  $\text{OK}$  key for a few seconds;
4. Release the  $\text{OK}$  key as soon as “dEF !” stops flashing; All the default values are restored except for the parameters from P016 to P022;
5. At the end of the operation display returns to P007.

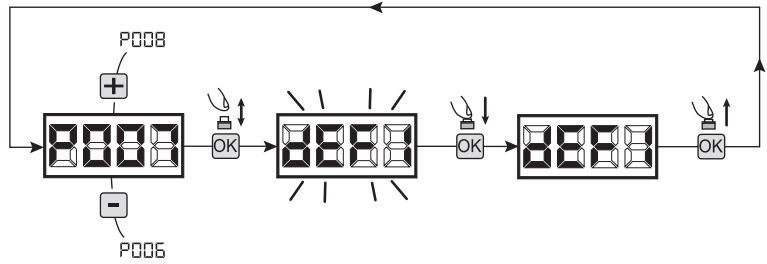

**Warning:** After you restore the default parameters, you must program the control panel again and adjust all operating parameters.

### 7.2 Restoring “I/O” setting (Input/Output)

1. Scroll through the parameters with the buttons  $\oplus$  and  $\ominus$  until the display shows P010;
2. Confirm by pressing on the  $\text{OK}$  key;
3. When “dEF 2” is flashing, press the  $\text{OK}$  key for a few seconds;
4. Release the  $\text{OK}$  key as soon as “dEF 2” stops flashing; All the default values only for the parameters from P016 to P022 are restored;
5. At the end of the operation display returns to P010.

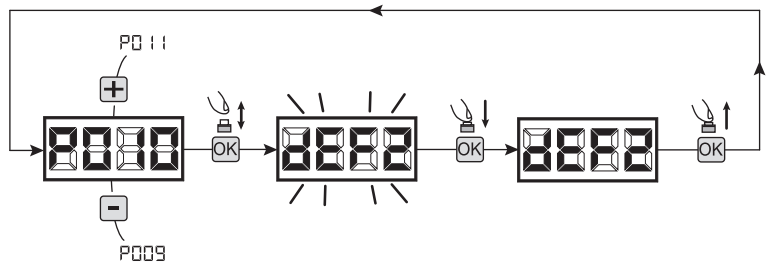

## 8 Locking-Unlocking access to programming

By using a “dip-switch” remote (regardless of the type of remotes already memorized) it’s possible to lock-unlock access to the programming of the control panel to avoid tampering. The remote setting is the locking-unlocking code verified by the control board.

### 8.1 Locking access to programming

1. Scroll through the parameters with the buttons  $\oplus$  and  $\ominus$  until the display shows P008;
2. Access the parameter by pressing the button  $\text{OK}$ ;
3. The display shows alternately the writing P-□□ / F-EE to indicate that the control board is waiting for the transmission of the block code;
4. Within 10 seconds press CH1 on the “TX Master”, the display shows P-□□ / bL□□ before returning to the list of parameters;
5. Access to programming is locked.

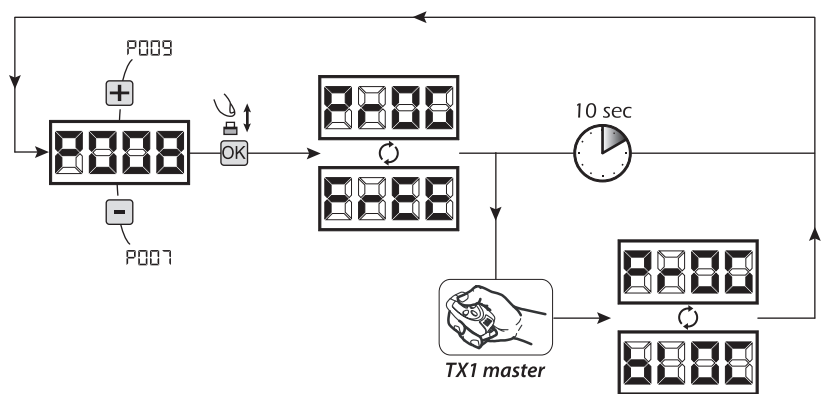

**WARNING** Programming lock/unlock can also be set via Smartphone using the DEAIstaller APP. In this case, an installer code is set (other than zero) that can only be unlocked via APP.

### 8.2 Unlocking access to programming

1. Scroll through the parameters with the buttons **+** and **-** until the display shows P008;
2. Access the parameter by pressing the button **OK**;
3. The display shows alternately the writing P<sub>r</sub>00/bL00 to indicate that the control board is waiting for the transmission of the unlocking code;
4. Within 10 sec. press the CH1 of the "TX Master", the display shows P<sub>r</sub>00/FrEE before returning to the list of parameters;
5. Access to programming is unlocked.

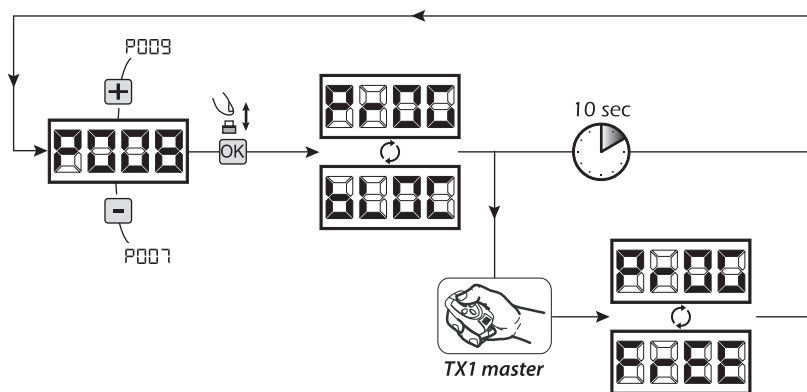

### 8.3 Unlocking access to programming and global reset

**WARNING! This procedure involves the loss of all stored settings.**

The procedure allows the unlocking of the control panel without having to know its unlocking code.

Following this release, you must program the control panel again and adjust all operating parameters, in particular, remember to properly set the configuration of parameters. You will also need to repeat the measurement of impact forces to ensure the installation compliance to standards.

1. Scroll through the parameters with the buttons **+** and **-** until the display shows P008;
2. Access the parameter by pressing the button **OK**;
3. The display shows alternately the writing P<sub>r</sub>00/bL00;
4. Press the button **OK**, the display shows the flashing writing FrEE ;
5. Press the button again and hold for 5 seconds (releasing it before, the procedure is terminated): The display shows the fixed writing FrEE followed by dEF ↓, before returning to the list of parameters;
6. Access to programming is unlocked.

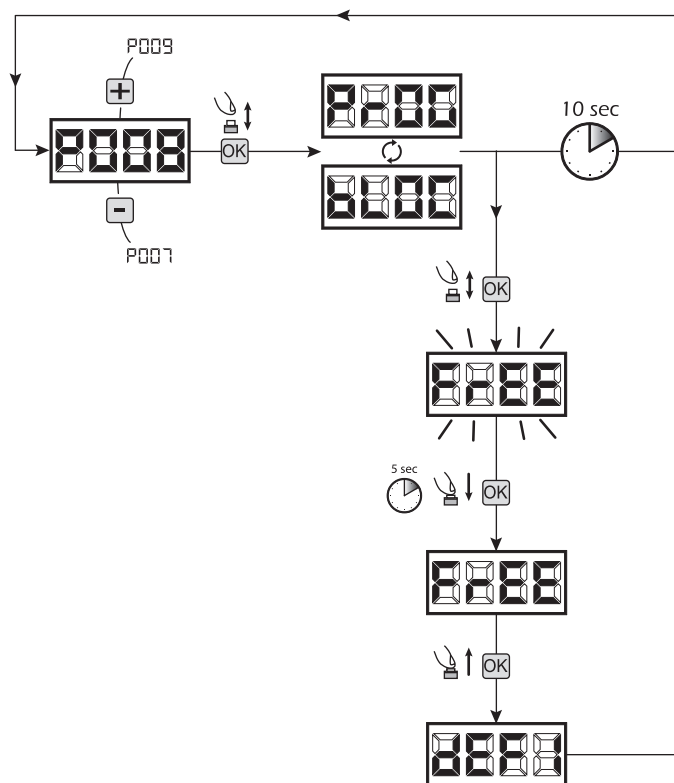

**WARNING** At the end of the procedure, the display will be blocked on flashing "CL - !" and motor stroke learning must be carried out again before any other operation can be carried out.

## 9 Downloading/uploading data memory

### 9.1 Downloading data to an external memory unit (DOWNLOAD)

1. Scroll down the parameters with **+** and **-** keys until you visualize P011;
2. Press the **OK** key, the display visualizes the word “**d n L d**” flashing;
3. Press the **OK** again and continue pressing it for 5 sec (if you release it before this period, the procedure is stopped);
4. Release the **OK** key as soon as the word “**d n L d**” stops flashing;

All the control panel configurations (TYPE, parameters, remotes, operators stroke, etc..) are saved in the external memory unit;

**Warning:** If there is any data in the external memory, during the memory download they will be overwritten.

5. At the end of the operation display returns to P011.

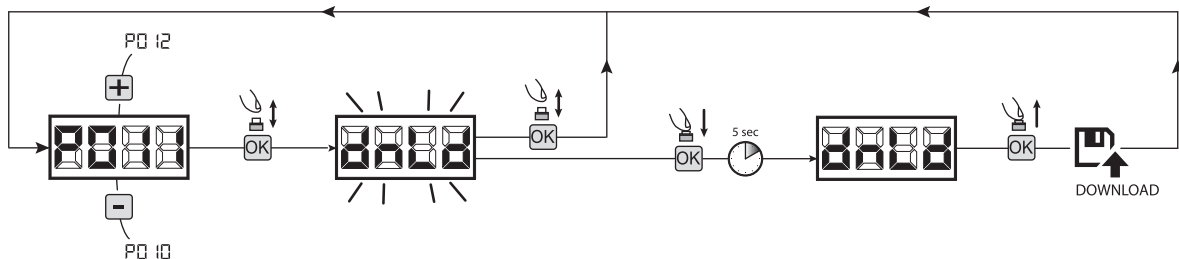

### 9.2 Uploading data from an external memory unit (UPLOAD)

1. Scroll down the parameters with **+** and **-** keys until you visualize P012;
  2. Press the **OK** key, the display visualizes the word “**U P L d**” flashing;
  3. Press the **OK** again and continue pressing for 5 sec (if you release it before this period, the procedure is stopped);
  4. Release the **OK** key as soon as the word “**U P L d**” stops flashing;
- All the control panel configurations (TYPE, parameters, remotes, operators stroke, etc..) contained in the external memory unit are uploaded in the connected control panel;
5. At the end of the operation display returns to P012.

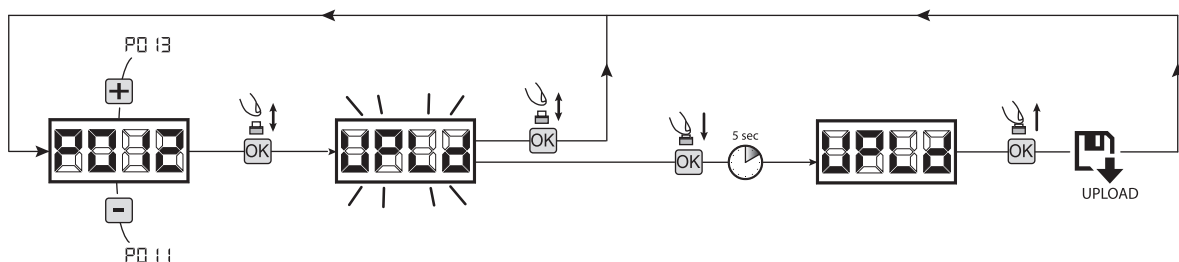

**WARNING** If you are not connected to any MEMONET units or if the connecting cable is disconnected during the data transfer operation, the display will visualize **E r r**, then the control unit is entirely reset and the display shows the word “TYPE” flashing. Refer to the MEMONET instruction to restore command unit functioning.

## 10 Inputs configuration

Where the installation requires different commands and / or additional to the standard ones described by plan, you can configure each input for the operation desired (eg. START, PHOTOS, STOP, etc ...).

1. Scroll down the parameters with the **+** and **-** to see that corresponding to the desired one:
  - P019=for INPUT 1;
  - P020=for INPUT 2;
  - P021=for INPUT 3;
  - P022=for INPUT 4;
2. Confirm by pressing on the **OK** key to get access to the parameter (eg. P020);
3. Scroll down with the **+** and **-**, keys to set the value corresponding to the desired operation (refer to table “Input Configuration parameters” on page 44);
4. Confirm by pressing on the **OK** key (display shows again P020).
5. Execute the new connection to the input just reconfigured.

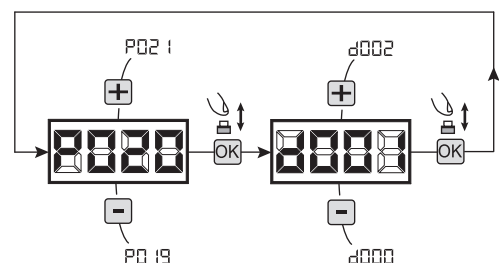

## 11 Programming complete

**WARNING** At the end of the programming procedure, **re-introduce Jumper J4, until “- - -” is shown on the display** and close the lid of the electric box. The automatism is now in stand-by for normal operating commands.

## 8 MESSAGES SHOWN ON THE DISPLAY

WORKING STATUS MESSAGES		
Mess.	Description	
----	Gate is closed	
_   _	Gate is opened	
OPEn	Opening under way	
CLoS	Closing under way	
StEP	While in step-by-step mode, the control board awaits further instructions after a start command	
StOP	Stop input intervened or an obstacle is detected with limited inversion duration (P055 > 0 or P056 > 0)	
⌋ ⌋	Board in BOOT-MODE: Indicates that the firmware is corrupted or updating. To restore the firmware, use the DEAIInstaller APP and make sure NET-NODE is corrected to the correct port. <b>Warning: When updating the firmware, all data in the board memory (settings and radio commands) are lost. Make sure you have backed up the memory to be restore data after the update.</b>	
rESP	Position reset under way: the research of the closing stop (in low speed) has started	
ERROR MESSAGES		
Mess.	Description	Possible solutions
BLoc URt	Board programming attempted when a NET-NODE device is connected.	Turn off power, disconnect the NET-NODE from the communication port and turn back on;
Err3	External photocells and/or safety devices are activated or out of order.	- Make sure that all safety devices and/or photocells installed are working properly.
Err4	Possible fault/overheating in the control unit's power circuit.	Turn off power for several minutes and turn back on. Give a start command: if the message is repeated, replace the control unit.
Err5	Time-out operators run: The engine/s exceeded the maximum operating time (4min) without ever stopping.	- Give a start pulse to start the position reset procedure; - Ensure that this operation is successful.
Err6	Time-out obstacle detection: With anti-crushing sensor disabled, was still detected the presence of an obstacle that prevents movement of the leaf for a period of 10 seconds more.	- Make sure there are no specific frictions and / or obstacles during the run; - Give a start pulse to initiate a position reset procedure; - Verify that the operation is completed successfully.
Err7	Operators mouvement not detected.	- Make sure that operators and encoders connections are well done. - If this error appears again, replace the control panel.
Err9	No/interrupted communication with remote memory board (also NET-EXP or NET-NODE).	- Check that the connecting cable of the external memory card is connected properly. - If you are performing a data transfer operation (DOWNLOAD / UPLOAD), make sure that it is not interrupted (eg by unplugging the card before the end of the operation). <b>Please note:</b> the interruption of an UPLOAD, also involves a total RESET of the control unit.
Err10 Err11	Possible fault/overheating in the control unit's power circuit.	Turn off power for several minutes and turn back on. Give a start command: if the message is repeated, replace the control unit.
Err12	Possible malfunction in the control unit's power circuit or in the encoder circuit.	Check the wiring of the encoder and the motor. Shut the power supply off and on again. Give a start command: if the message is repeated, perform the following checks. - Enter P003 and move the door using the + and - buttons. - If the door moves at maximum speed and the display shows Err7, replace the motor's encoder card. - If the motor still remains stationary, replace the control unit.
Err15	Sensitive regulation parameters were edited via DEAIInstaller APP without running motor stroke learning at the end of the operation.	Run motor stroke learning (P003) first to be able to run any other operation.
Err16	You are trying to learn a motor with a number of encoder channels different than the value set in parameter P029.	Set the parameter value P029 correctly.
Err81	NET-NODE connected to the incorrect communication port.	Connect NET-NODE to the correct port according to that indicated in the control unit diagram.

## 9 COMMISSIONING

The commissioning phase is extremely important for ensuring maximum system safety, as well as legal and regulatory compliance, namely with all the requirements of EN 12445, which establishes the testing methods for gate automation units.

**DEA System** would like to emphasize that any system installation, cleaning or repair operations must only be carried out by qualified personnel, who must conduct all the tests necessary based on the risks present;

Check prior to activation by repeatedly opening and closing the door and automation unit, and verifying their perfect functionality.

This will allow you to verify that there are no installation or adjustment errors. Check the impact force during the obstacle detection phase, as required by EN 12445.

### 9.1 Instructions for the user

Ensure that the owner/user is instructed during commissioning regarding safe operation of the machine. It is recommended to explain or demonstrate the functions directly on the object:

- Safe use of the plant with respect of all safety regulations;
- The position and function of all commands and safety devices and their effect during the various operating conditions;
- The safe use of the manual release mechanism;
- The arrangement and meaning of warnings;
- Operational conditions.

**WARNING** Using spare parts not indicated by **DEA System** and/or incorrect re-assembly can create a risk to people, animals and property and also damage the product. For this reason, always use only the parts indicated by **DEA System** and scrupulously follow all assembly instructions.

### 9.2 Unlocking and Manual operation

In the event of any system anomalies or power failures, release the gear motor (Fig. 5) and manoeuvre the door leaf manually.

**WARNING** The efficacy and safety of manual operation of the automation is guaranteed by **DEA System** only if the installation has been installed correctly and with original accessories.

## 10 MAINTENANCE

Good preventive maintenance and regular inspection ensure long working life. In the table below you will find a list of inspections/maintenance operations to be programmed and executed periodically.

Consult the TROUBLE-SHOOTING table whenever anomalies are observed in order to find the solution to the problem and contact **DEA System** directly whenever the solution required is not provided.

INTERVENTION TYPE	PERIODICITY
Lightly lubricate the chain and the movable pins. Remove any excess lubricant. The toothed belt must not be lubricated. Clean the automation unit with a dry cloth or a vacuum cleaner	6 months
Check screw tightness	6 months
Check the tension of any belts or chains (see Pic. 4)	6 months

TROUBLE-SHOOTING	
Description	Possible solutions
By activating the open or close command, the door does not move and the operator electric motor does not start to operate.	The operator is not powered correctly; check the connections, the fuses and the conditions of the power supply cables and replace/repair them, if necessary. If the door does not close, also check that the photocells operate correctly.
By activating the open command, the motor starts to operate by the gate does not move.	Check that the motor release is closed (see Pic. 5). Check that the motor does not push in the opposite direction; this could be caused by inverted wiring.
During the movement the operator functions in a jerky manner, it is noisy and stops half-way or does not start.	The door does not have free movement; release the motor and organise the points of rotation. The power of the gear motor could be insufficient with respect to the features of the door; check the choice of model.

## 11 PRODUCT DISPOSAL

### DISASSEMBLY

The automation unit must be dismantled by qualified personnel, in accordance with the current accident prevention and safety regulations, and with reference to the installation instructions, but in the reverse order. Before initiating the disassembly operations, disconnect the electrical power and make sure it cannot be reconnected.

### DISPOSAL

The automation unit must be disposed of in accordance with the current local and national waste disposal regulations. The product (or its individual parts) must not be disposed of together with other household waste materials.

 **WARNING** In line with EU Directive 2012/19/EG for waste electrical and electronic equipment (WEEE), this electrical product must not be disposed of as unsorted municipal waste. Please dispose of this product by returning it to your local municipal collection point for recycling.

PAR.	PROCEDURE	SETTABLE VALUES
PEE1	Unused parameter	
PEE2	Unused parameter	
PEE3	Memorization of the motors' stroke	
PEE4	Deletion of transmitters	
PEE5	Transmitters memorizing	
PEE6	Search and deletion of a transmitter	
PEE7	Restoring the operating parameters	
PEE8	Lock access to programming	
PEE9	How to learn connected DE@NET devices (unused at the moment)	
PEE0	Restoring the "I/O" configurations (input/output)	
PEI1	Downloading data on the external memory unit	
PEI2	Uploading data from an external memory unit	
PEI3	Visualisation of inputs and operations-counter status	
PEI4	Unused parameter	
PEI5	Unused parameter	

PROGRAMMING PROCEDURES

PAR.	PARAMETER DESCRIPTION	SETTABLE VALUES	DEFAULT VALUES	
			SPACE	SPACE L - XL - XXL
PEI6	INPUT_2 selectioning input type		000	000
PEI7	Selection of pushbutton ▲ operation	<ul style="list-style-type: none"> <li>• 000: IN2 type=free contact</li> <li>• 001: IN2 type=constant resistance 8K2</li> </ul>	▲	003
PEI8	Selection of pushbutton ▼ operation		▼	004
PEI9	INPUT_1 operating selection	<ul style="list-style-type: none"> <li>• 000: NONE (unused parameter)</li> <li>• 001: START (start)</li> <li>• 002: PED. (pedestrian)</li> <li>• 003: OPEN (separated open)</li> <li>• 004: CLOSE (separated close)</li> <li>• 005: OPEN_PM (man present open)</li> <li>• 006: CLOSE_PM (man present close)</li> <li>• 007: ELOCK_IN (configurable Output 2. See P062)</li> <li>• 008: PHOTO 1 (photocell 1)</li> <li>• 009: PHOTO 2 (photocell 2)</li> <li>• 010: SAFETY 1 (safety rib 1)</li> <li>• 011: STOP (lock) / SAS INPUT (with NET_EXP only)</li> <li>• 012: FCA1 (opening limit switches Mot1)</li> <li>• 013: Not Available</li> <li>• 014: FCC1 (closing limit switches Mot1)</li> <li>• 015: Not Available</li> <li>• 016: SAFETY 2 (safety rib 2)</li> <li>• 017: OPEN_INT (with NET_EXP only)</li> <li>• 018: OPEN_EXT (with NET_EXP only)</li> <li>• 019: AUX_IN (configurable Output 1. See P066)</li> <li>• 020: SAFETY INHIBITION (SAFETY inhibition)</li> </ul>	IN1	008
PEI20	INPUT_2 operating selection		IN2	001
PEI21	INPUT_3 operating selection	IN3	000	
PEI22	INPUT_4 operating selection	IN4	000	

INPUTS CONFIGURATION PARAMETERS

		SPACE	SPACE L - XL - XXL
INPUTS CONFIGURATION PARAMETERS	P023	Allocation of CHANNEL 1 of remotes	CH1 • 000: NONE (unused) • 001: START (start) • 002: PEDESTRIAN (pedestrian) • 003: OPEN (separated open) • 004: CLOSED (separated close) • 005: Unused • 006: Unused • 007: ELOCK_IN (configurable Output 2. See P062) • 008: AUX_IN (configurable Output 1. See P066) • 009: COURTESY_IN (courtesy light control) • 010: STOP
	P024	Allocation of CHANNEL 2 of remotes	CH2
	P025	Allocation of CHANNEL 3 of remotes	CH3
	P026	Allocation of CHANNEL 4 of remotes	CH4
OPERATORS CONFIGURATION PARAMETERS	P027	Selection of type of remotes	• 000: HCS fix-code • 001: HCS rolling-code • 002: Dip-switch • 003: DART
	P028	Selection type of operators	• 000: ADVANCE - SPACE - VIP 60 • 001: SPACE L - VIP 80 • 002: ADVANCE XL - SPACE XL - VIP XL • 003: SPACE XXL
	P029	Select encoder type	• 001: 1 channel encoder • 002: 2 channel encoder
	P030	Unused parameter	/
	P031	Operators speed adjustment during slow-down while opening	15%.....100%
	P032	Operators speed adjustment during the stroke while opening	15%.....100%
	P033	Operators speed adjustment during the stroke while closing	15%.....100%
	P034	Operators speed adjustment during slow-down while closing	15%.....100%
	P035	Slow down duration adjustment while opening	0%.....80%
	P036	Slow down duration adjustment while closing	0%.....80%
	P037	Operator 1 force adjustment while opening (if = 100% obstacle detection deactivated)	1%.....100%
	P038	Operator n.1 force adjustment while closing (if = 100% obstacle detection deactivated)	1%.....100%
OPERATING PARAMETERS	P039	Secondary force adjustment in closing: adjusts the motor's force during the last part of the closing movement defined by P058	1%.....100%
	P040	Unused parameter	/
	P041	Automatic closing times adjustment (if = 0 automatic closing deactivated)	Osec.....255sec
	P042	Pedestrian automatic closing time adjustment (se = 0 pedestrian automatic closing deactivated)	Omin.....255min
	P043	Pedestrian stroke duration adjustment	5%.....100%
	P044	Pre-flashing time adjustment	Osec.....10sec
	P045	Unused parameter	/
	P046	Unused parameter	/
	P047	Operator 1 force adjustment while opening (if = 100% obstacle detection deactivated)	1%.....100%
	P048	Operator n.1 force adjustment while closing (if = 100% obstacle detection deactivated)	1%.....100%

			SPACE	SPACE L - XL - XXL
P047	Collectivity function: if it is activated it deactivates both opening and closing inputs for the whole duration of automatic opening and closing		000	000
P048	Unused parameter		/	/
P049	"Reversal" mode selection (during the manoeuvre a command impulse reverse the movement) or "step by step" (during the manoeuvre a command impulse stops the movement). A next impulse restart the operator to the opposite direction.		001	001
P050	PHOTO 1 PHOTO input functioning: If=0: photocell enabled while closing and starting when the gate is stopped; if=1 photocells are always enabled; if=2 photocells are enabled while closing only. When enabled, its activation provokes: the inversion (while closing), the stop (while opening) and prevent the starting (when gate is closed). If = 3-4-5, the operation is identical to values 0-1-2 but with the "close immediately" function enabled: in any case, when opening and / or pausing time, removing a any obstacle the gate will end the opening maneuver before closing it automatically after a 2 second fixed delay.		002	002
P051	PHOTO 2		002	002
P052	Operation mode selection of the warning light output: If> 1 "courtesy light" (output ON during each movement, OFF when the motor stops, after the setting delay)		030	030
P053	Unused parameter		/	/
P054	"soft start" function: motors accelerate gradually until they reach the set speed, avoiding sudden departures <b>Warning:</b> Set the value of P054=2 only if the obstacle detection is disabled (P037 and/or P038 =100)		001	001
P055	Adjust the inversion on obstacle period (detected by internal anti-crushing sensor or by the safety input when activated); If = 0 it makes a complete inversion, If> 0 indicates the duration (in seconds) of the run, after inversion resulting from detection of an obstacle during the opening.		003	003
P056	Adjust the inversion on obstacle period (detected by internal anti-crushing sensor or by the safety input when activated); If = 0 it makes a complete inversion, If> 0 indicates the duration (in seconds) of the run, after inversion resulting from detection of an obstacle during the closing.		003	003
P057	Unused parameter		/	/
P058	Duration adjustment for the secondary force in closing; adjusts the duration of the last part of the closing movement, in which the force is managed separately with P039. The value is expressed in number of revolutions of the rotor.		050	050
P059	Adjustment of the stop-margin in closing; adjusts the duration of the last part of the closing movement, in which an obstacle is seen as a stop, causing the motor to stop without reversal on the obstacle. The value is expressed in number of revolutions of the rotor.		015	015
P060	Force adjustment in the stop margin in closing, its duration is set through P059.		050	050
P061	"Energy saving" mode: If=1 after 10sec of inactivity, the control panel turns the 24V outputs and the display off that will be turned on at first command received (use recommended battery-powered and / or solar panel).		000	000
P062	OUTPUT_2 functioning selection: If=0 "boost" output for electric lock power supply art. 110; If=1 fixed flashing output (for flashing lights with internal intermittent circuit); If=2 intermittent flashing output; If=3 Fixed open gate LED" (output always On when the gate is open, OFF at the end of a closure manoeuvre); If=4 Intermittent open gate LED" (slow intermittent output during opening and fast during closing, always ON with gate open, always OFF only at the end of a closing manoeuvre); If=5 Courtesy light" (output ON during every movement, OFF when the motor stops, after the delay set); If=6 24V output for electric lock in fixed mode; If=7 24V output for electric lock in inverted mode; If=8 output for accessories power supply; If=9 24V commanded by ELOCK_IN input in impulse mode; If=10 24V output commanded by ELOCK_IN input in bistable mode; If=11 24V output commanded by ELOCK_IN input in timed mode (the value set indicates the switch-off delay in seconds). <b>Warning:</b> If P062=8, output functioning is determined by the functioning envisioned in parameters P061 (Energy Saving) and P071 (Safety devices autotest). <b>Warning:</b> To adjust the activation/deactivation times in the 000   006   007 modes, use parameter P064.		004	004

OPERATING PARAMETERS

		SPACE	SPACE L - XL - XXL
P053	Unused parameter	/	/
P054	Electric lock duration adjustment If P062 or P066= 000 I006, adjust the activation time of the LOCK output; If P062 or P066= 007, adjust the deactivation time of the LOCK output;	002	002
P055	Maintenance Operations-counter; if = 0 reset the counter and disables the intervention request , if> 0 indicates the number of operations (x 500) to be made before the control panel executes a 4 second additional pre-flash to indicate the need of maintenance. i.g.: If P065 = 050, operations number = 50x500 = 25000 operations <b>Warning:</b> Before you set a new value of the counter-manoeuvers maintenance, the same must be reset by setting P065= 0 and only later P065 = "new value".	000	000
P055	OUTPUT_1 functioning selection: If=1 fixed flashing output (for flashing lights with internal intermittent circuit); If=2 intermittent flashing output; If=3 Fixed open gate LED" (output always On when the gate is open, OFF at the end of a closure manoeuvre); If=4 Intermittent open gate LED" (slow intermittent output during opening and fast during closing, always ON with gate open, always OFF only at the end of a closing manoeuvre); If=5 Courtesy light" (output ON during every movement, OFF when the motor stops, after the delay set); If=6 24V output for electric lock in fixed mode; If=7 24V output for electric lock in inverted mode; If=8 output for accessories power supply; If=9 24V output commanded by AUX_IN input in impulse mode; If=10 24V output commanded by AUX_IN input in bistable mode; If>10 24V output commanded by AUX_IN input in timed mode (the value set indicates the switch-off delay in seconds). <b>Warnings:</b> If P066=8, output functioning is determined by the functioning envisioned in parameters P061 (Energy Saving) and P071 (Safety devices autotest). <b>Warning:</b> To adjust the activation/deactivation times in the 006   007 modes, use parameter P064.	001	001
P057	Operation of the SFT input: If = 0 safety edge always enabled, if = 1 safety edge enabled only while closing, if = 2 safety edge enabled only while closing and before any movement, if = 3 safety edge enabled only when opening, if = 4 safety edge enabled only while opening and before any movement; as for the obstacle detection with internal anti-crushing sensor, also the activation of the inputs SFT1 and SFT2 causes the complete or partial reversal as set by P055 (duration of inversion on obstacles while opening, and P056 (duration of reversal on obstacle while closing)	001	001
P058	SAFETY 2	001	001
P059	Unused parameter	/	/
P070	Adjustment of acceleration durability <b>Warning:</b> if soft start is activated, the acceleration is deactivated independently from P070 value.	008	008
P071	Safeties self-test: if = 0 24V output with autotest disabled; if = 1 24V output for safeties with self-test (it turn the output off and check the contact opening before each maneuver). <b>Warning:</b> In order to work in self-test mode, all devices must be connected to the configurable 24V output (7-8 for OUTPUT_1) (16-17 for OUTPUT_2) with P062 and/or P066 = 8, and be wired and aligned before the motor stroke learning (P003).	000	000
P072	Activation of SAS function ( <b>with NET_EXP only</b> ): SAS output is connected to an input STOP / SAS INPUT of a second control panel, causing the operation "trap man" (disabling the opening of the second door as long as the first is not completely closed). If this parameter is enabled after a reset, it performs an automatic RESP during which the SAS output is not activated. If limit switches are present and they are crushed after a reset, the RESP is not executed. <b>Warning:</b> if both doors are manually unlocked and moved from the closed position creates the interlock condition. You will then need to manually close at least one of the two doors.	000	000

OPERATING PARAMETERS

		SPACE	SPACE L - XL - XXL
P073	<p><b>Forced "Hold to Run":</b> if this function is enabled, all inputs configured as OPEN and CLOSE change automatically also to OPEN UP and CLOSE UP (hold-to-run commands) if activated and kept active in case a safety contact (photocell and/or safety edge) is triggered. This function thus allows to control the automation even in case the safety devices are faulty. If the input is no longer maintained active, the automation returns to automatic operation.</p> <p>When using safety edges configured as SAFETY1 or SAFETY 2, this function is not compatible with the values 001 and 003 of parameters P067 and P068.</p> <p>For security reasons, we recommend that you DO NOT use this function in case there are any clocks/timers connected to the inputs configured as OPEN or CLOSE.</p>	<ul style="list-style-type: none"> <li>• 000: function disabled</li> <li>• 001: function enabled (forces switch to Hold-to-run mode when safeties are triggered and OPEN/CLOSE commands are maintained)</li> </ul>	000
P074	<p><b>Photocells inhibition:</b> if this function is enabled, it is possible, once the position of the photocells has been detected, to disable their action in the area between the position of the photocells and the "door-closed" position (this happens both during opening and closing). The point where the inhibition starts is memorized by triggering of the photocells during the automatic closing phase of the stroke learning (P003). For the inhibition to be effective, the photocells must be wired as PHOTO 1.</p>	<ul style="list-style-type: none"> <li>• 000: inhibition disabled</li> <li>• 001: inhibition enabled (photocells are always ignored in the area between the detection point and the "door-closed" position)</li> </ul>	000
P075	Unused parameter	/	/
P076	<p>Enable Save port position in memory at server shutdown (see RESP in screen error table).</p> <p>if P076=0 at server shutdown, the port position is not saved and the position is always reset at next boot.</p> <p>if P076=1 at server shutdown, the port position is saved in the memory and the position is not reset at next boot.</p> <p><b>Warning:</b> Perform a new motor stroke learning (P003) every time you change the parameter.</p>	<ul style="list-style-type: none"> <li>• 000: RESP active</li> <li>• 001: RESP not active</li> </ul>	001
P077	<p>Electronic positioning brake.</p> <p><b>Caution:</b> If active (P077=1), it is <b>NECESSARY</b> to set parameter P076 = 0 and install the mechanical stop (Art. AB/FM not supplied) on the rail in the open position.</p>	<ul style="list-style-type: none"> <li>• 000: not active</li> <li>• 001: active</li> </ul>	000
P078 --- P099	<p><b>Configuration parameters dedicated to the expansion card NET_EXP (for a detailed description of the parameters, refer to the instruction manual).</b></p>		

**OPERATING PARAMETERS**

**Esempio di installazione tipica - Example of typical installation - Exemple d'installation typique - Installationsbeispiel - Ejemplo de instalación típica - Exemplo de instalação típica - Przykład standardowego systemu automatyzacji - Пример типового монтажа**

**DEA** System fornisce queste indicazioni che si possono ritenere valide per un impianto tipo ma che non possono essere complete. Per ogni automatismo, infatti, l'installatore deve valutare attentamente le reali condizioni del posto ed i requisiti dell'installazione in termini di prestazioni e di sicurezza; sarà in base a queste considerazioni che redigerà l'analisi dei rischi e progetterà nel dettaglio l'automatismo. - **DEA** System provides the following instructions which are valid for a typical system but obviously not complete for every system. For each automatism the installer must carefully evaluate the real conditions existing at the site. The installation requisites in terms of both performance and safety must be based upon such considerations, which will also form the basis for the risk analysis and the detailed design of the automatism. - **DEA** System fournit ces indications que vous pouvez considérer comme valables pour une installation-type, même si elles ne peuvent pas être complètes. En effet, pour chaque automatisations, l'installateur doit évaluer attentivement les conditions réelles du site et les pré-requis de l'installation au point de vue performances et sécurité ; c'est sur la base de ces considérations qu'il rédigerà l'analyse des risques et qu'il concevra l'automatisation d'une manière détaillée. - Diese Angaben von **DEA** System können als gültig für eine Standardanlage angesehen werden, können aber nicht erschöpfend sein. So muss der Installationsfachmann für jedes Automatiksystem sorgfältig die Voraussetzungen des Installationsortes sowie die Leistungs- und Sicherheitsanforderungen an die Installation abwägen; aufgrund dieser Überlegungen muss er die Risikobewertung erstellen und genau das Automatiksystem entwickeln. - **DEA**

System facilita estas indicaciones que pueden considerarse válidas para una instalación tipo pero que no pueden considerarse completas. El instalador, en efecto, tiene que evaluar atentamente para cada automatismo las reales condiciones del sitio y los requisitos de la instalación por lo que se refiere a prestaciones y seguridad; en función de estas consideraciones redactará el análisis de riesgos y efectuará el proyecto detallado del automatismo. - **DEA** System fornece estas indicações que podem ser consideradas válidas para o equipamento padrão, mas que podem não ser completas. Para cada automatismo praticamente o técnico de instalação deverá avaliar com atenção as condições reais do sítio e os requisitos da instalação em termos de performance e de segurança; será em função destas considerações que realizará uma análise dos riscos e projectará. - **DEA** System dostarcza wskazówek, do wykorzystania w typowej instalacji ale nie będą one nigdy kompletne. Dla każdego typu automatyki, instalator musi sam oszacować realne warunki miejsca montażu i wymogi instalacyjne mając na uwadze przepisy dotyczące bezpieczeństwa. Na podstawie zebranych informacji będzie w stanie przeanalizować zagrożenia mogące wystąpić i zaprojektować w szczególności automatyzację. - **DEA** System предлагает рекомендации, которые действительны для типовой системы, но, очевидно, не обязательны для каждой конкретной установки. Для каждого конкретного случая установщик должен тщательно оценить реальные условия. Устройства для установки оцениваются с точки зрения производительности и безопасности, которые необходимы для анализа рисков и детального проектирования системы автоматизации.

Pos.	Descrizione - Description - Description - Beschreibung - Descripción - Descrição - Opis - Описание
1	Selettore a chiave anticasso - Anti lock-picking key switch - Sélecteur à clé anti-intrusion - Einbruchfester Schlüsselschalter - Selector a llave antisabotaje - Interruptor de chave burglar - Przelącznik kluczowy wandaloodporny - Замковый выключатель
2	Radiocomando - Remote-control - Radiocommande - Funksteuerung - Radiocomando - Comando via rádio - Nadajnik - Пульт ДУ
3	Lampeggiante - Flashing light - Clignotant - Blinker - Lámpara - Intermitente - Lampa Ostrzegawcza - Сигнальная лампа
4	SPACE
5	Safety edge - Bord sensible - Berührungssensible Schaltleiste - Borde sensible - Dispositivo sensível de protecção - Listwa bezpieczeństwa - Ребро безопасности
6	Fotocellule - Photocells - Photocellules - Fozzellen - Fococélulas - Fotocélulas - Fotokomórki - фотоэлементы

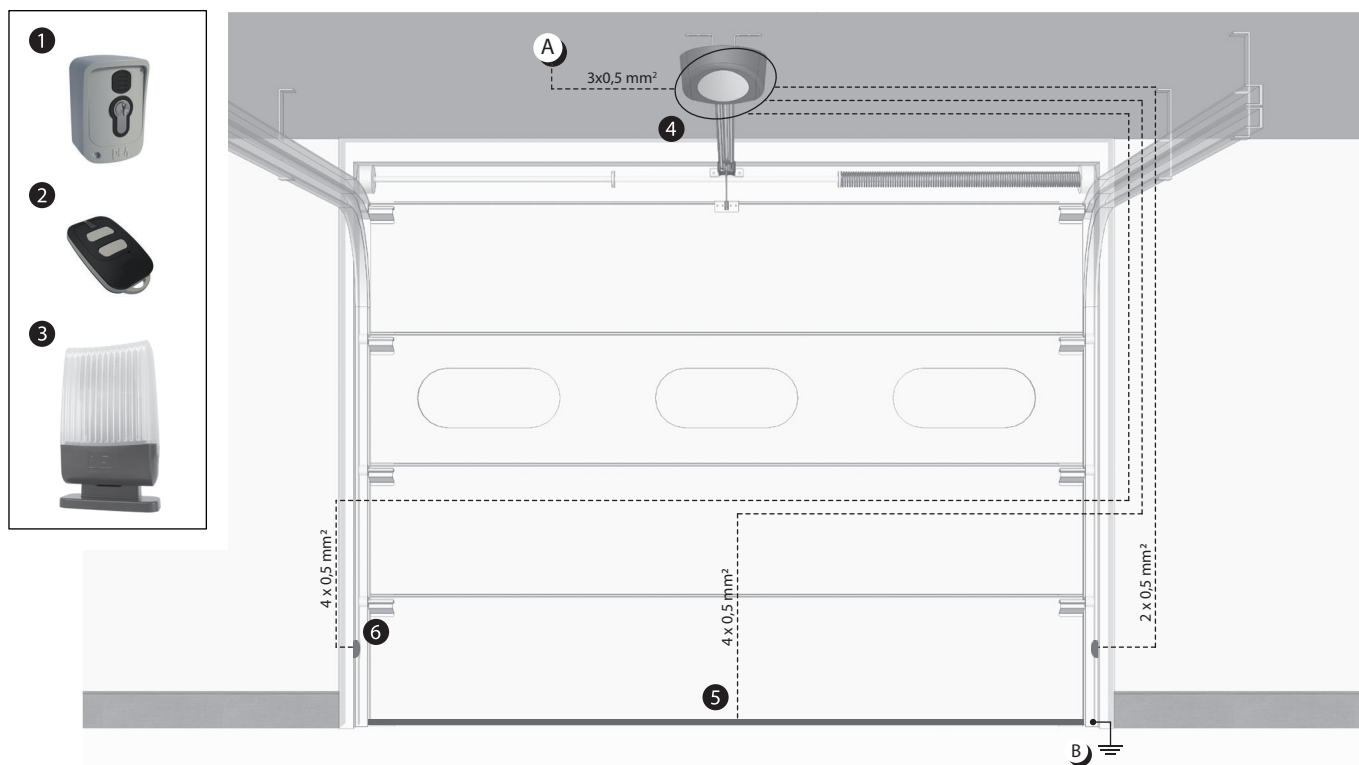

**A) Collegarsi alla rete 230 V  $\pm$  10% 50-60 Hz tramite un interruttore onnipolare o altro dispositivo che assicuri la onnipolare disinserzione della rete, con una distanza di apertura dei contatti  $\geq$  3 mm. - **Make** the 230V  $\pm$  10% 50-60 Hz mains connection using an omnipolar switch or any other device that guarantees the omnipolar disconnection of the mains network with a contact opening distance of 3 mm. - **Connectez-vous** au réseau 230 V  $\pm$  10% 50-60 Hz au moyen d'un interrupteur onnipolaire ou d'un autre dispositif qui assure le débranchement omnipolaire du réseau, avec un écartement des contacts égal à 3 mm. - **Den** Anschluss an das 230 V  $\pm$  10% 50-60 Hz Netz mit einem Allpolschalter oder einer anderen Vorrichtung vornehmen, durch die eine allpolige Netzunterbrechung bei einem Öffnungsabstand der Kontakte von  $\geq$  3 mm gewährleistet wird. - **Efectuar** la conexión a una línea eléctrica 230 V  $\pm$  10% 50-60 Hz a través de un interruptor omnipolar u otro dispositivo que asegure la omnipolar desconexión de la línea, con 3 mm de distancia de abertura de los contactos. - **Ligue** na rede de 230 V.  $\pm$  10% 50-60 Hz mediante um interruptor omnipolar ou outro dispositivo que assegure que se desliga de maneira omnipolar da rede, com abertura dos contactos de pelo menos 3 mm. de distância. - **Podłączyć** się do sieci 230 V  $\pm$  10% 50-60 Hz poprzez przelącznik jednobiegunowy lub inne urządzenie które zapewni brak zakłóceń w sieci, przy odległości między stykami  $\geq$  3 mm. - **Подключайтесь** к сети 230V  $\pm$  10% 50-60 Гц с помощью многополюсного выключателя или используйте любое другое устройство, которое гарантирует многополюсное отключение питающей сети с расстоянием между контактами от  $\geq$  3 мм и больше.**

**B) Collegare a terra tutte le masse metalliche - All metal parts must be grounded - Connectez toutes les masses métalliques à la terre - Alle Metallteile erden - Conectar con la tierra todas las masas metálicas - Realize ligação à terra de todas as massas metálicas - Uziemić wszystkie elementy metalowe. - Все металлические части должны быть заземлены.**

1

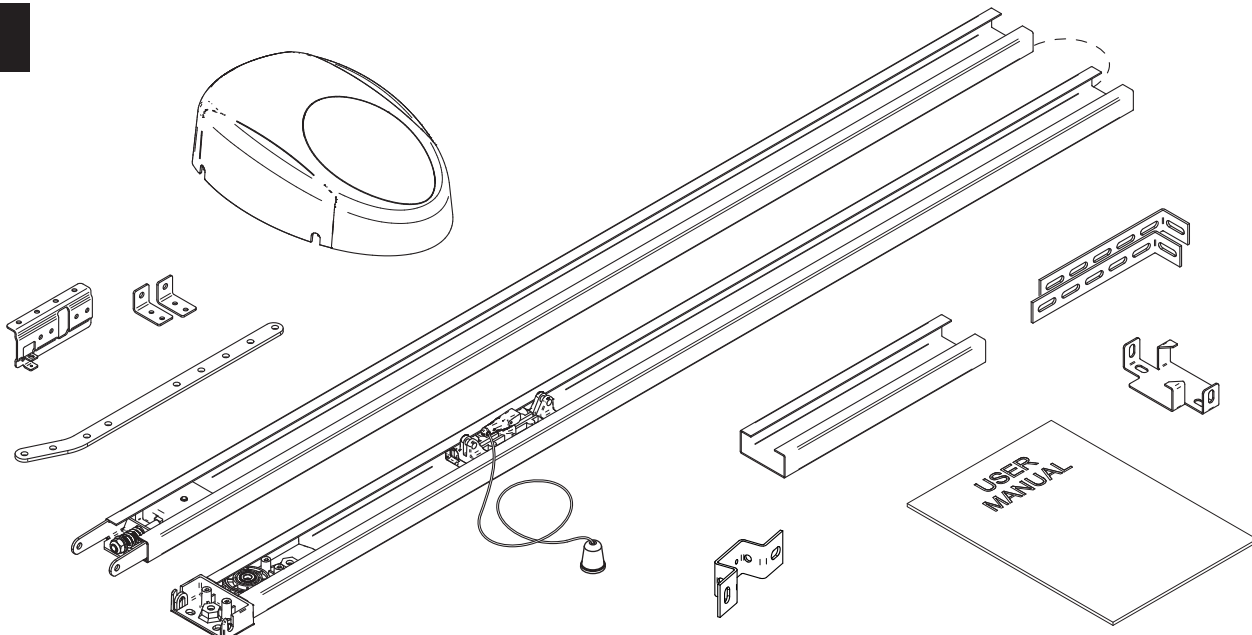

2

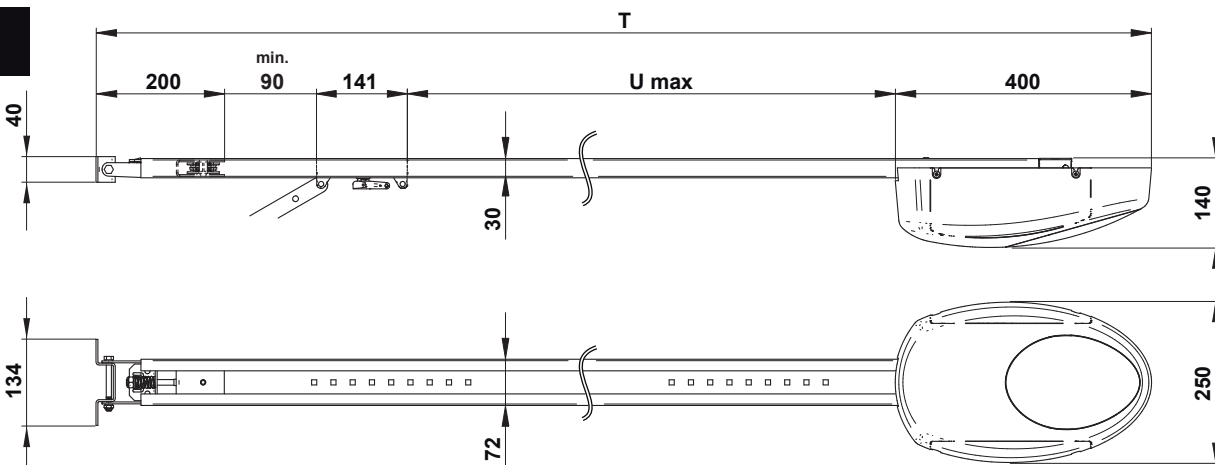

Cod.	U max	T
AB15	2468	3245
AB16	2668	3445
AB20	3468	4245

3

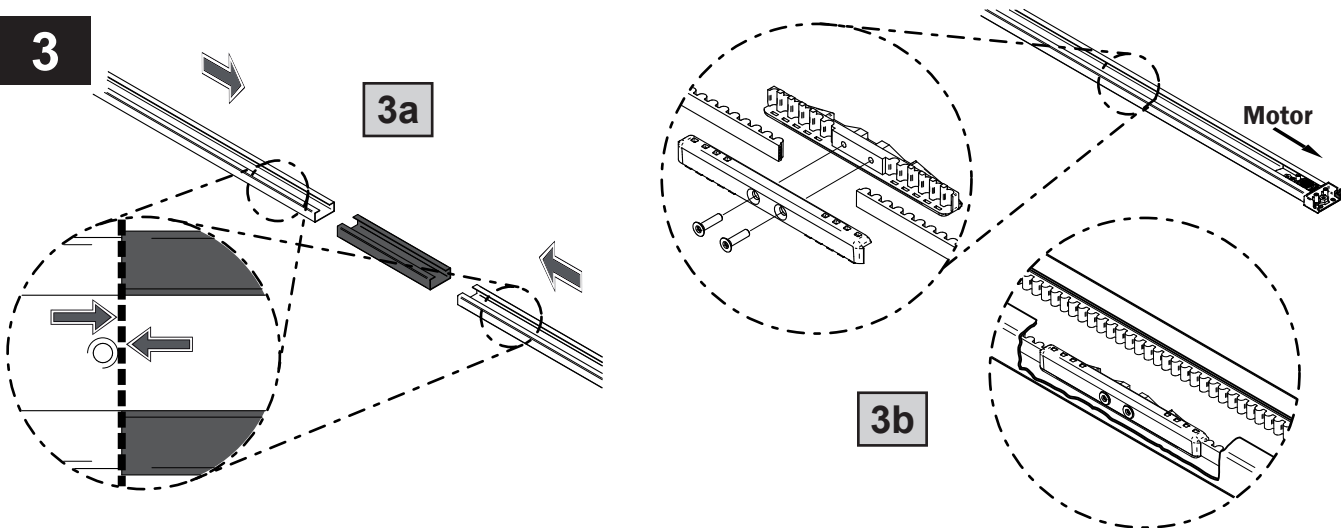

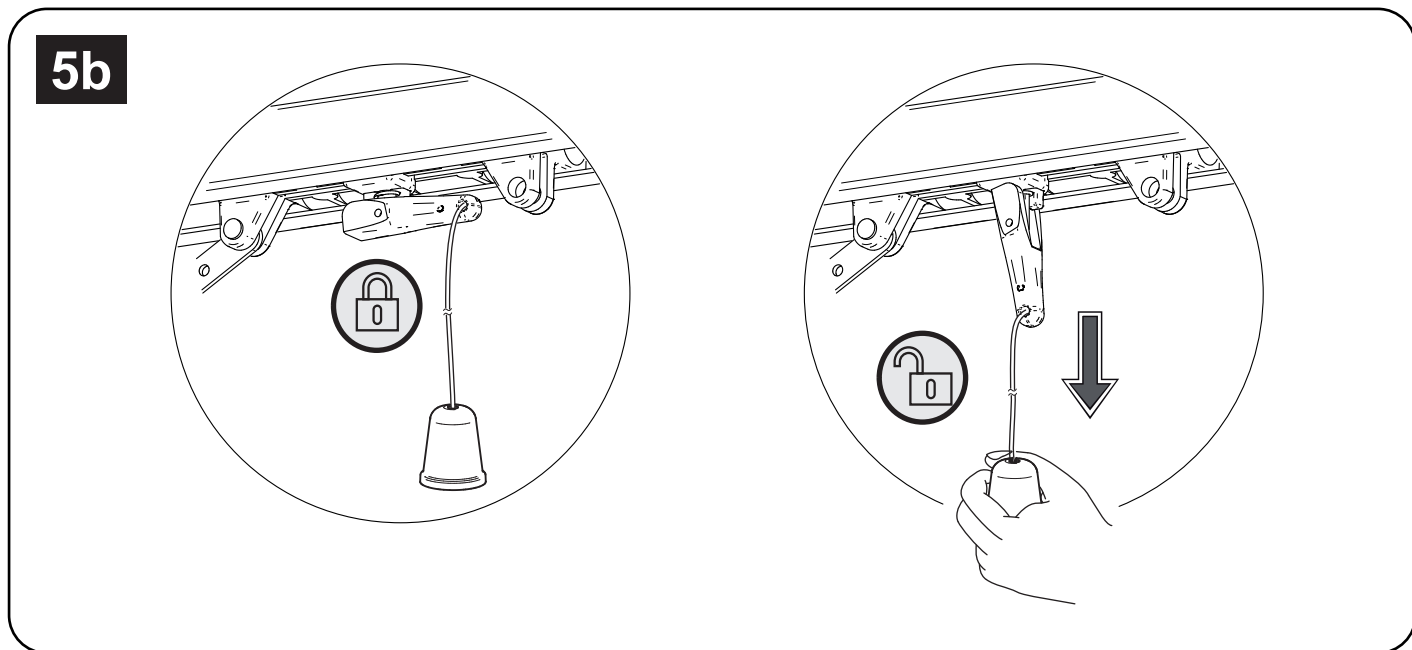
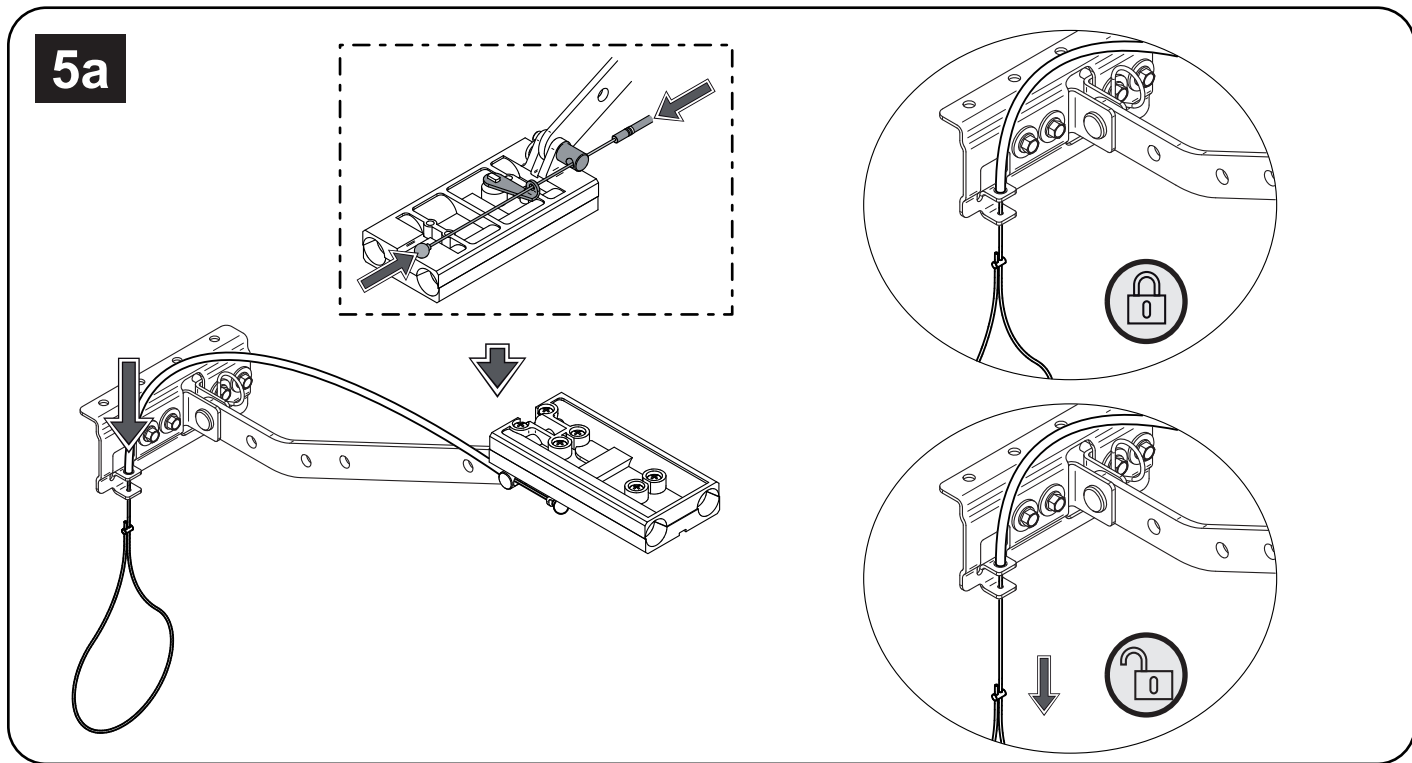
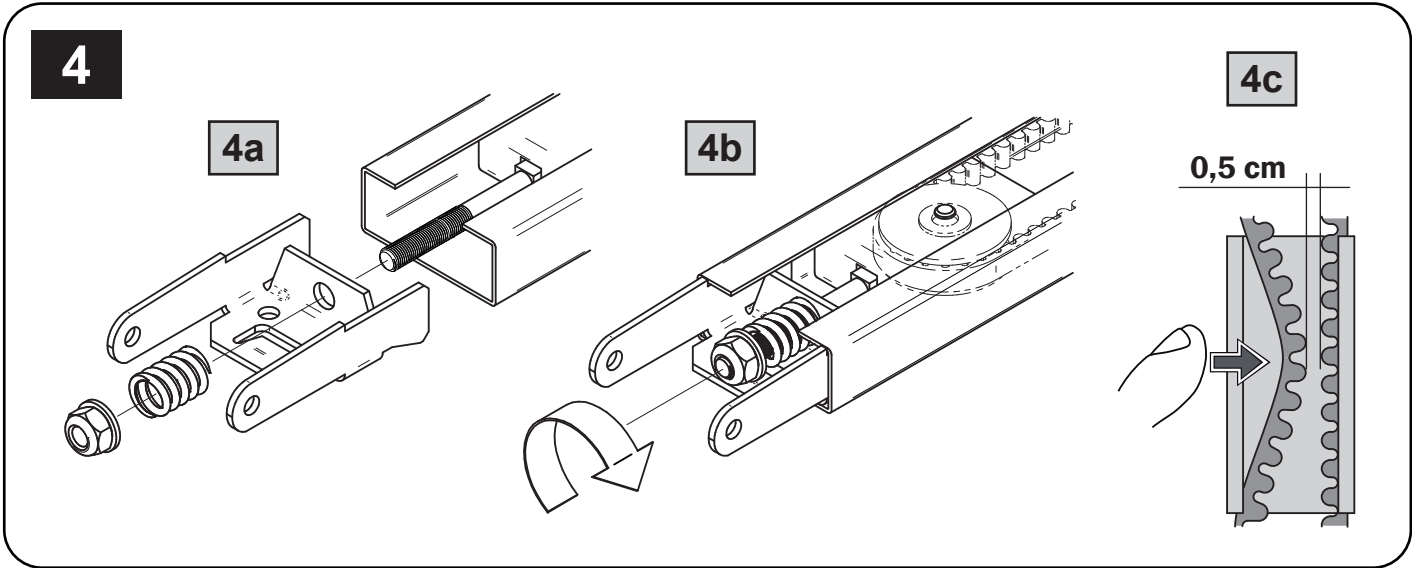

6

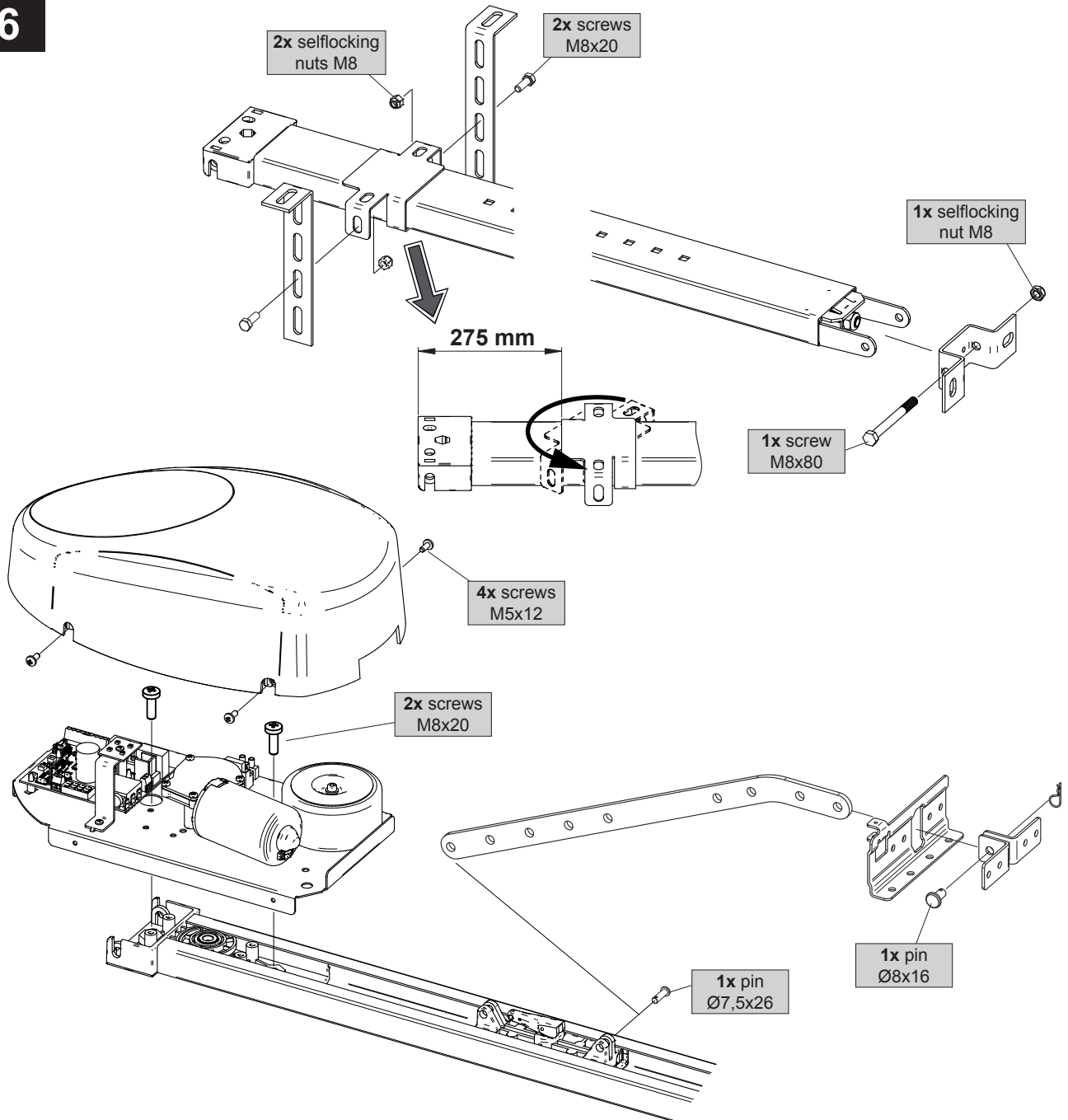

7

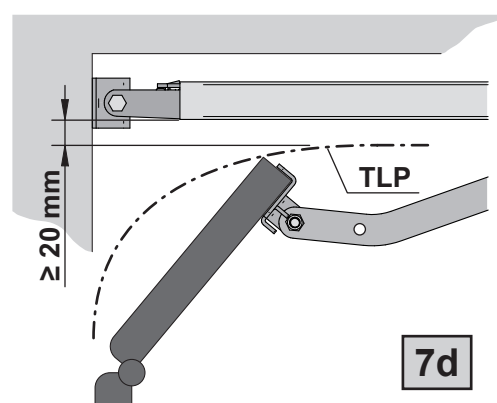
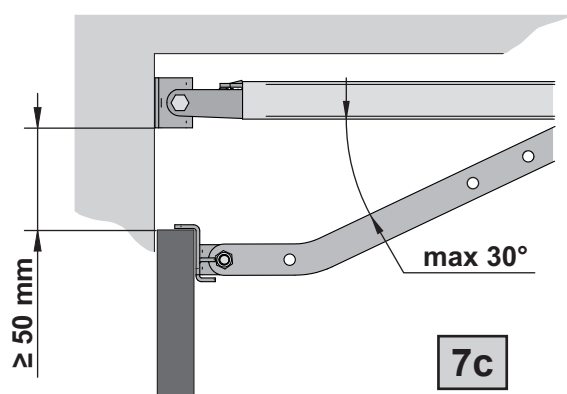
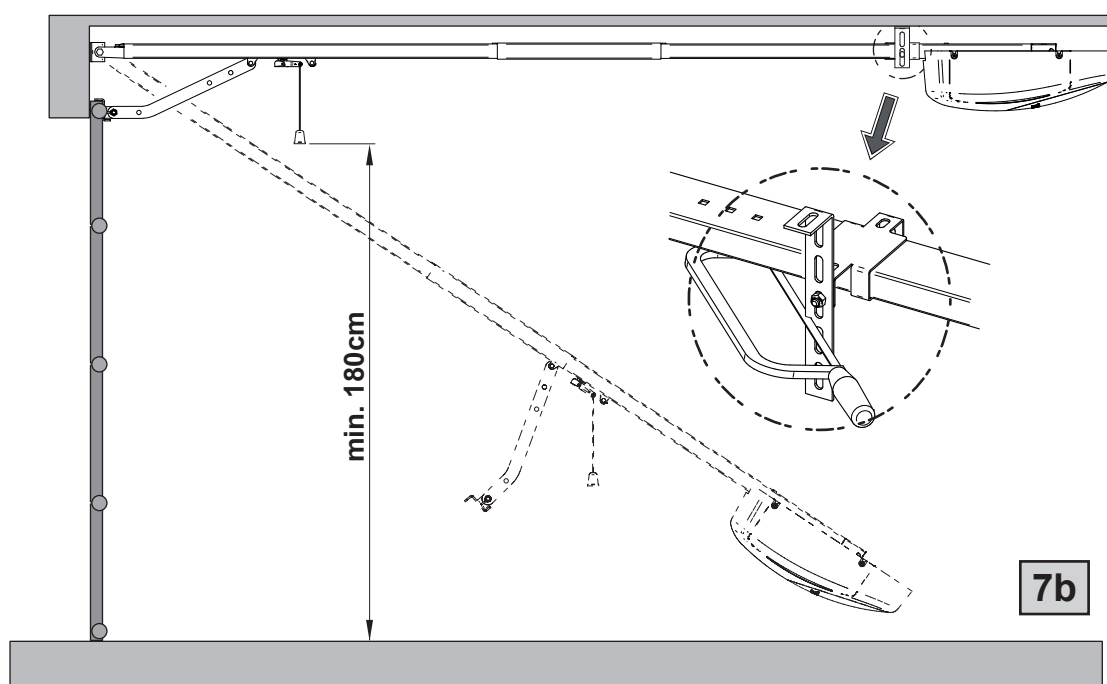
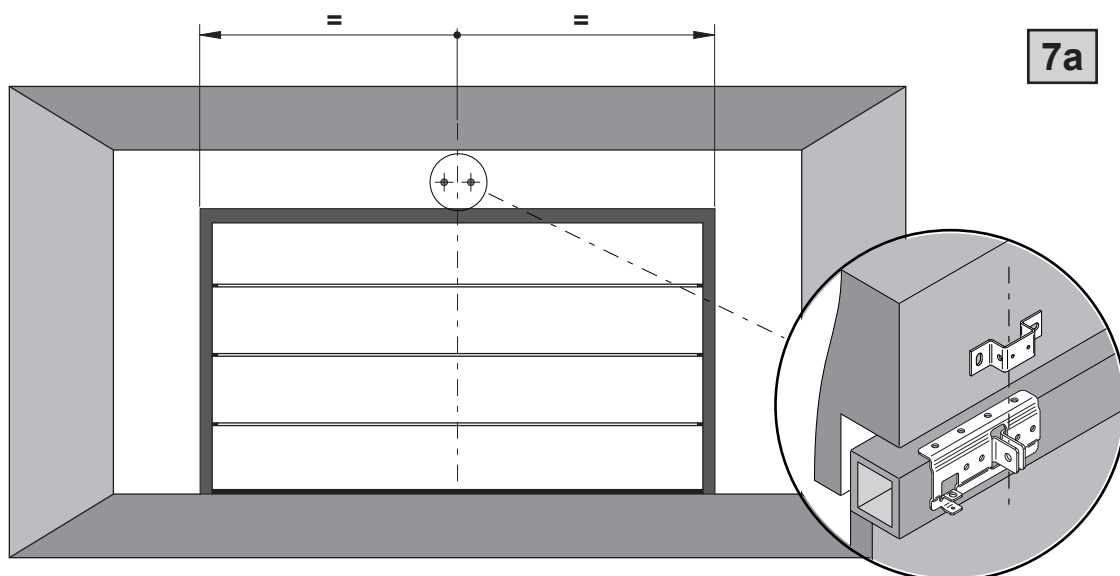

8

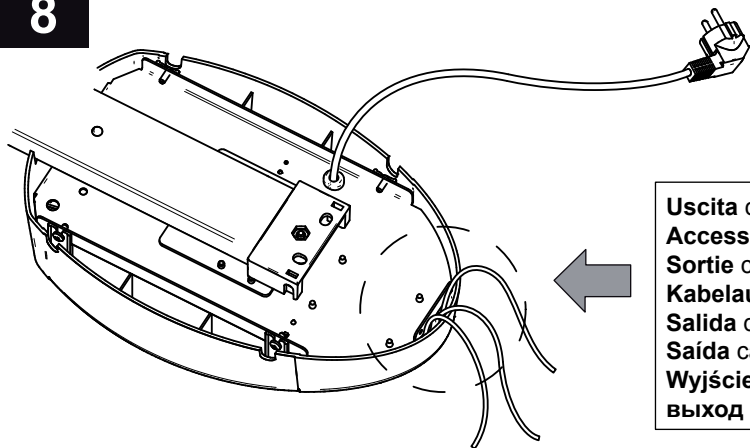

**Uscita** cavi per connessione accessori/comandi  
**Accessories** /control devices connection cables plug  
**Sortie** câbles pour connexion accessoires/commandes  
**Kabelausgang** für den Anschluss von Zubehör / Kontrollen  
**Salida** de cables para la conexión de accesorios/mandos  
**Saída** cabos para conexão acessórios/comandos  
**Wyjście** kabla do podłączenia akcesoriów / kontrole  
**выход** кабеля для подключения аксессуаров / управления







Tabella "ACCESSORI PRODOTTO", Table "PRODUCT ACCESSORIES", Tableau "ACCESSOIRES PRODUITS", Tabelle „PRODUKTZUBEHÖR“, Tabla "ACCESORIOS PRODUCTO", Tabela "ACESSÓRIOS DO PRODUTO", Tabela "AKCESORIA DODATKOWE", Таблица "АКСЕССУАРЫ ИЗДЕЛИЯ".

Article Code	Descrizione, Description, Description, Beschreibung, Descripción, Descrição, Opis	
<b>721/AB</b> 639321		<b>Sblocco base - Basic release - Débloccage base - Bowdenzug Standard - Desbloqueo base - Desbloqueio base - Odblokowanie podstawy - Базовая разблокировка</b>
<b>721D</b> 639322		<b>Dispositivo di sblocco esterno con cavo - External release device with cable - Dispositif de déverrouillage externe avec câble - Externes Entriegelungsgerät mit Kabel - Dispositivo de desbloqueo exterior con el cable - Dispositivo de liberação externa com cabo - Zewnętrzne urządzenie zwalniające z kablem - Внешнее устройство выпуска с кабелем</b>
<b>721M</b> 639311		<b>Maniglia sblocco per sezionali - Release handle for sectional doors - Manette de débloccage pour portes sectionnelles - Entriegelungsgriff für Federschwingtore - Manija de desbloqueo para seccionales - Manilha desbloqueio para seccionadas - Uchwyt odblokowania dla bram segmentowych - Ручка разблокировки секционных ворот</b>
<b>722</b> 639340		<b>Braccio curvo per porte basculanti debordanti a contrappesi - Curved arm for up-and-over hinged doors with counter-weight - Bras courbe pour portes basculantes en saillie à contrepoids - Kurvenarm für Gegengewichtsgaragentore - Brazo curvo para puertas basculantes sobrepasantes de contrapesos - Braço curvo para portas basculantes de contrapesos - Ramię krzywe do bramy z przeciwwagą - Изогнутый кронштейн для поворотных выступающих ворот с противовесами</b>
<b>723</b> 639350		<b>Adattatore braccio per porte sezionali - Arm adapter for sectional doors - Adaptateur de bras pour portes sectionnelles - Schubstangen-Verlängerung für Sektionaltore - Adaptador brazo para puertas seccionales - Adaptador braço para portas seccionadas - Adapter ramienia dla bram segmentowych - Переходник кронштейна для секционных ворот</b>
<b>761C</b> 639371		<b>Dispositivo di sblocco a filo con serratura copriforo - Release device flush with hole cover lock - Dispositif de débloccage coplanaire avec la serrure cache-trou - Bowdenzug mit Schloss für Lochabdeckung - Dispositivo de desbloqueo a nivel con cerradura cubreorificio - Dispositivo de desbloqueio com cabo com fechadura tampa de furo - Urządzenie odblokowania z zamkiem zakrywającym otwór - Устройство разблокировки на одном уровне с замком с закрытой замочной скважиной</b>
<b>762C</b> 639372		<b>Dispositivo di sblocco a filo con serratura - Release device flush with lock - Dispositif de débloccage coplanaire avec la serrure - Entriegelungsgriff für Sektionaltore mit Bowdenzug - Dispositivo de desbloqueo a nivel con cerradura - Dispositivo de desbloqueio com cabo com fechadura - Urządzenie odblokowania z zamkiem - Устройство разблокировки на одном уровне с замком</b>
<b>BLINDOS</b> 665000		<b>Contenitore sicurezza predisposto per sblocco a filo - Safety enclosure to place external unlocking device handle - Boîte de sécurité avec prédisposition déverrouillage par câble - Aufputz Sicherheitskasten, vorbereitet für Notentriegelung via Bowdenzug - Caja de seguridad para colocar dispositivo de desbloqueo externo - Caixa de segurança para colocar dispositivos de desbloqueio externos - Kaseta zabezpieczająca pod zewnętrzny mechanizm odblokowujący - Контейнер безопасности предназначен для очистки релиз.</b>

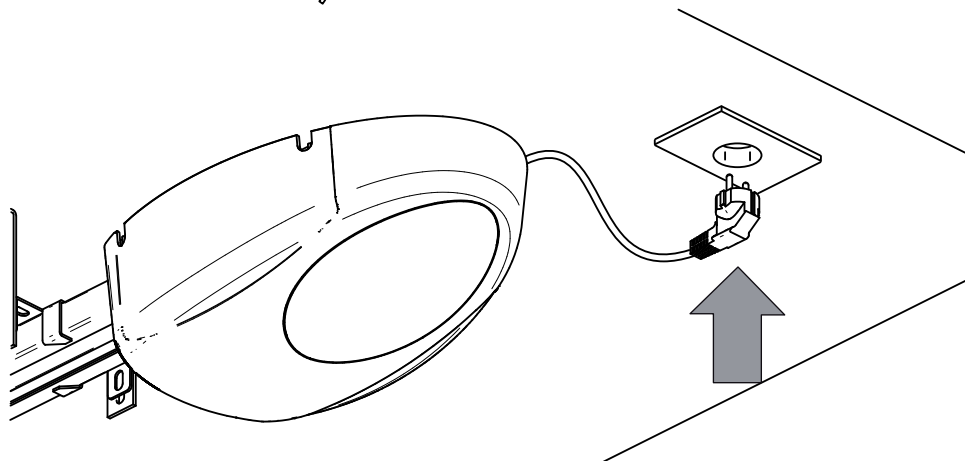
<b>240E</b> 179006		<b>Antenna</b> supplementare per SPACE - <b>Additional</b> antenna for SPACE - <b>Antenne</b> supplémentaire pour SPACE - <b>Zusatzantenne</b> für SPACE - <b>Antena</b> suplementaria para SPACE - <b>Antena</b> supplementare para SPACE - <b>Dodatkowa</b> antena dla SPACE - <b>Дополнительная</b> антенна для SPACE	
<b>AB16</b> 636090		<b>1,6 m</b> + <b>1,6 m</b>	<b>STEEL</b>  <b>Gruppo</b> binario (2 pezzi) - <b>Track</b> unit (2 pieces) - <b>Groupe</b> rail (2 éléments) - <b>Deckenschiene</b> (geteilt) - <b>Grupo</b> carril (2 piezas) - <b>Conjunto</b> calha (2 peças) - <b>Zespół</b> szyn (2 elementy) - <b>Узел</b> рельса (2 отрезка)
<b>AB20</b> 636093		<b>2 m</b> + <b>2 m</b>	
<b>AB/EXTENSION</b> 636301		<b>1,6 m</b>	
<b>AB/BRACKET</b> 639381		<b>Staffe</b> supplementari per il binario - <b>Additional</b> brackets for rail supports - <b>Supports</b> supplémentaires pour le rail - <b>Zusätzliche</b> Halter für Schiene - <b>Soportes</b> adicionales para el binario - <b>Suportes</b> adicionais para o binário - <b>Dodatkowe</b> wsporniki do binarnego - <b>Дополнительные</b> кронштейны для бинарной	
<b>AB/FM</b> 639382		<b>Fermi</b> meccanici per sezionali - <b>Mechanical</b> stops for sectional doors - <b>Boutée</b> mécaniques pour portes sectionnelles - <b>Mechanische</b> Sperre für sektionaltore - <b>Topes</b> mecánicos para puertas seccionales - <b>Fins-de-course</b> mecânicos para portas seccionais - <b>Krańcówki</b> mechaniczne dla bramy segmentowe - <b>Папа</b> механических стопов для секционные ворота	

## INSTRUCTIONS FOR THE FINAL USER

This guide has been prepared for the final users of the automatism; the installer is required to deliver this guide and illustrate its contents to the person in charge of the system. The latter must then provide similar instruction to all the other users. These instructions must be carefully conserved and easily available for consultation when required.

Good preventive maintenance and frequent inspection ensures the long working life of the product. Contact the installer regularly for routine maintenance and in event of anomaly.

### SAFETY RULES

1. Always keep a safe distance from the automatism during operation and never touch any moving part.
2. Prevent children from playing near the automatism.
3. Perform the control and inspection operations prescribed in the maintenance schedule and immediately stop using the automatism whenever signs of malfunction are noted.
4. Never disassemble parts of the product! All maintenance and repair operations must be performed only by qualified personnel.
5. The release operation must sometimes be performed in emergencies! All users must be instructed on the use of the release mechanism and the location of the release keys.

### SPACE RELEASE MECHANISM

All SPACE models have a release device that is activated by pulling the handle indicated in Fig. 5 downwards; at this point, the door is free to move if there are no other obstructions present. To restore the motor work condition, move the handle upwards and **move the door manually until the release runner is blocked again.**

**WARNING:** During this operation gate may present uncontrolled movement: operate with extra care so to avoid any risk.

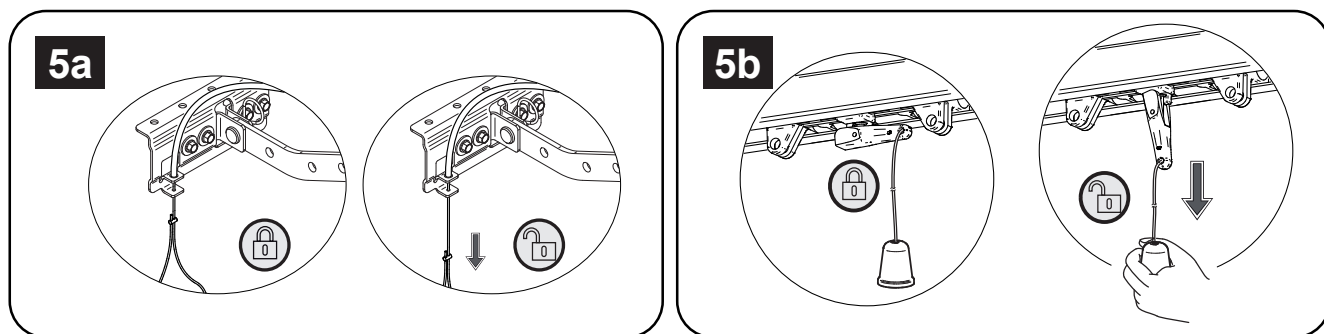

### CLEANING AND INSPECTIONS

The only operation the user can and must do is to remove any obstacle hindering the door or SPACE operator travel range. **Warning! Always disconnect the power supply whenever performing operations on the gate!**

# EU Declaration of Conformity (DoC)

and Declaration of Incorporation of "quasi-machines" (pursuant to the Machinery Directive 2006/42/CE, Att.II, B)

Company name:	DEA SYSTEM S.p.A.
Postal address:	Via Della Tecnica, 6
Postcode and City:	36013 Piovene Rocchette (VI) - ITALY
Telephone number:	+39 0445 550789
E-Mail address:	deasystem@deasystem.com

declare that the DoC is issued under our sole responsibility and belongs to the following product:

Apparatus model/Product:	SPACE – SPACE L - SPACE/XL - SPACE/XXL
Type:	Sectional door electromechanical operator
Batch:	See the label on the back of the user manual

The object of the declaration described above is in conformity with the relevant Union harmonisation legislation:

## Directive 2006/42/CE (MD Directive)

- It is declared that the relevant technical documentation has been drawn-up in compliance with attachment VII B.
- It is also declared that the following essential health and safety requirements have been respected: 1.1.1 - 1.1.2 - 1.1.3 - 1.1.5 - 1.2.1 - 1.2.6 - 1.3.1 - 1.3.2 - 1.3.3 - 1.3.4 - 1.3.7 - 1.3.9 - 1.5.1 - 1.5.2 - 1.5.4 - 1.5.5 - 1.5.6 - 1.5.7 - 1.5.8 - 1.5.10 - 1.5.11 - 1.5.13 - 1.6.1 - 1.6.2 - 1.6.4 - 1.7.2 - 1.7.3 - 1.7.4 - 1.7.4.1 - 1.7.4.2 - 1.7.4.3.
- The undersigned declares that the afore-mentioned "partly-completed machinery" cannot be commissioned until the final machine, into which it has been incorporated, has been declared compliant with the Machinery Directive 2006/42/CE.
- On duly justified request, the manufacturer commits to transmitting the information regarding the "partly-completed machinery" to the national authorities without prejudice to their intellectual property rights.

The product is in compliance with the applicable parts of the following regulations:

EN 13241-1:2003 + A1:2011(\*) ; EN 12445:2002; EN 12453:2002; EN 12978:2003 + A1:2009.

(\*): Pending review of the standard, no presumption of conformity to points 4.22, 4.26, 4.32, 4.33, 4.34, 4.36

## Directive 2014/53/UE (RED Directive)

The following harmonised standards and technical specifications have been applied:

Title:	Date of standard/specification
EN 61000-6-2	2005 + EC:2005
EN 61000-6-3	2007 + A1:2011
EN 301-489-1	2017 (v2.2.0)
EN 301-489-3	2017 (v2.2.1)
ETSI EN 300 220-1	V3.1.1
ETSI EN 300 220-2	V3.1.1
EN 60335-1	2012 + A11:2014
EN 60335-2-103	2015
EN 62233	2008

## Additional information

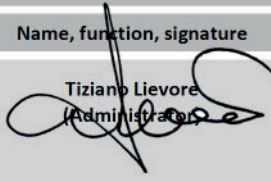
Signed for and on behalf of:		
Revision:	Place and date of issue:	Name, function, signature
00.01	Piovene Rocchette (VI) 25/05/18	 Tiziano Lievore (Administrator)



**BATCH**



**DEA SYSTEM S.p.A.**

Via Della Tecnica, 6 - 36013 PIOVENE ROCCHETTE (VI) - ITALY

**tel:** +39 0445 550789 - **fax:** +39 0445 550265

**Internet:** <http://www.deasystem.com> - **E-mail:** [deasystem@deasystem.com](mailto:deasystem@deasystem.com)